

Poorna Foundation



MATH

Practice Workbook

Grade 6

Copyright © by Poorna Foundation Organization

All rights reserved. No part of this publication may be reproduced or transmitted in any form or by any means, electronic or mechanical, including photocopy, recording, or any information storage and retrieval system, without permission in writing from the publisher.

Permission is hereby granted to individual teachers using the corresponding student's textbook or kit as the major vehicle for regular classroom instruction to photocopy complete student pages from this publication in classroom quantities for instructional use and not for resale.

Duplication of this work other than by individual classroom teachers under the conditions specified above requires a license. To order a book, Email contact@poornafoundation.org

Poorna Foundation Logo is trademark of Poorna Foundation Organization.

CONTENTS

Unit 1: NUMBER SENSE AND OPERATIONS

Chapter 1: Whole Number Applications

- 1.1 Estimate with Whole Numbers 1
- 1.2 Use Addition and Subtraction 2
- 1.3 Use Multiplication and Division . . . 3
- 1.4 Problem Solving Strategy:
Predict and Test 4
- 1.5 Algebra: Use Expressions 5
- 1.6 Algebra: Mental Math
and Equations 6

Chapter 2: Operation Sense

- 2.1 Mental Math: Use the Properties . . 7
- 2.2 Algebra: Exponents 8
- 2.4 Algebra: Order of Operations 9
- 2.5 Problem Solving Skill: Sequence
and Prioritize Information 10

Chapter 3: Decimal Concepts

- 3.1 Represent, Compare, and
Order Decimals 11
- 3.2 Problem Solving Strategy:
Make a Table 12
- 3.3 Estimate with Decimals 13
- 3.4 Decimals and Percents 14

Chapter 4: Decimal Operations

- 4.1 Add and Subtract Decimals 15
- 4.2 Multiply Decimals 16
- 4.4 Divide with Decimals 17
- 4.5 Problem Solving Skill: Interpret
the Remainder 18
- 4.6 Algebra: Decimal Expressions
and Equations 19

Unit 2: STATISTICS AND GRAPHING

Chapter 5: Collect and Organize Data

- 5.1 Samples 20
- 5.2 Bias in Surveys 21
- 5.3 Problem Solving Strategy:
Make a Table 22
- 5.4 Frequency Tables and
Line Plots 23
- 5.5 Measures of Central Tendency 24
- 5.6 Outliers and Additional Data 25
- 5.7 Data and Conclusions 26

Chapter 6: Graph Data

- 6.1 Make and Analyze Graphs 27
- 6.2 Find Unknown Values. 28
- 6.3 Stem-and-Leaf Plots
and Histograms 29
- 6.5 Box-and-Whisker Graphs 30
- 6.6 Analyze Graphs 31

Unit 3: FRACTION CONCEPTS AND OPERATIONS

Chapter 7: Number Theory

- 7.1 Divisibility 32
- 7.2 Prime Factorization. 33
- 7.3 Least Common Multiple and
Greatest Common Factor 34
- 7.4 Problem Solving Strategy:
Make an Organized List 35

Chapter 8: Fraction Concepts

- 8.1 Equivalent Fractions and
Simplest Form 36
- 8.2 Mixed Numbers and Fractions 37

8.3 Compare and Order Fractions	38
8.5 Fractions, Decimals, and Percents	39

Chapter 9: Add and Subtract Fractions and Mixed Numbers

9.1 Estimate Sums and Differences . . .	40
9.3 Add and Subtract Fractions	41
9.4 Add and Subtract Mixed Numbers	42
9.6 Subtract Mixed Numbers	43
9.7 Problem Solving Strategy: Draw a Diagram	44

Chapter 10: Multiply and Divide Fractions and Mixed Numbers

10.1 Estimate Products and Quotients	45
10.2 Multiply Fractions	46
10.3 Multiply Mixed Numbers	47
10.5 Divide Fractions and Mixed Numbers	48
10.6 Problem Solving Skill: Choose the Operation	49
10.7 Algebra: Fraction Expressions and Equations	50

Unit 4: ALGEBRA: INTEGERS

Chapter 11: Number Relationships

11.1 Understand Integers	51
11.2 Rational Numbers	52
11.3 Compare and Order Rational Numbers	53
11.4 Problem Solving Strategy: Use Logical Reasoning	54

Chapter 12: Add and Subtract with Integers

12.2 Algebra: Add Integers	55
12.4 Algebra: Subtract Integers	56

Chapter 13: Multiply and Divide with Integers

13.2 Algebra: Multiply Integers	57
13.3 Algebra: Divide Integers	58
13.4 Combine Operations with Integers	59

Unit 5: ALGEBRA: EXPRESSIONS AND EQUATIONS

Chapter 14: Expressions

14.1 Write Expressions	60
14.2 Evaluate Expressions	61
14.4 Expressions with Squares and Square Roots	62

Chapter 15: Addition and Subtraction Equations

15.1 Connect Words and Equations	63
15.3 Solve Addition Equations	64
15.4 Solve Subtraction Equations	65

Chapter 16: Multiplication and Division Equations

16.2 Solve Multiplication and Division Equations	66
16.3 Use Formulas	67
16.5 Problem Solving Strategy: Work Backward	68

Unit 6: GEOMETRY AND SPATIAL REASONING

Chapter 17: Geometric Figures

17.1 Points, Lines, and Planes	69
17.3 Angle Relationships	70
17.4 Classify Lines	71

Chapter 18: Plane Figures	
18.1 Triangles	72
18.2 Problem Solving Strategy: Find a Pattern	73
18.3 Quadrilaterals	74
18.4 Draw Two-Dimensional Figures	75
18.5 Circles	76

Chapter 19: Solid Figures	
19.1 Types of Solid Figures	77
19.2 Different Views of Solid Figures	78
19.3 Problem Solving Strategy: Solve a Simpler Problem	79

**Unit 7: RATIO, PROPORTION, PERCENT,
AND PROBABILITY**

Chapter 20: Ratio and Proportion	
20.1 Ratios and Rates	80
20.3 Problem Solving Strategy: Write an Equation	81
20.4 Algebra: Ratios and Similar Figures	82
20.5 Algebra: Proportions and Similar Figures	83
20.6 Algebra: Scale Drawings	84
20.7 Algebra: Maps	85

Chapter 21: Percent and Change	
21.1 Percent	86
21.2 Percents, Decimals, and Fractions	87
21.3 Estimate and Find Percent of a Number	88
21.5 Discount and Sales Tax	89
21.6 Simple Interest	90

Chapter 22: Probability of Simple Events	
22.1 Theoretical Probability	91
22.2 Problem Solving Skill: Too Much or Too Little Information	92
22.4 Experimental Probability	93

Chapter 23: Probability of Compound Events	
23.1 Problem Solving Strategy: Make an Organized List	94
23.2 Compound Events	95
23.3 Independent and Dependent Events	96
23.4 Make Predictions	97

Unit 8: MEASUREMENT

Chapter 24: Units of Measure	
24.1 Algebra: Customary Measurements	98
24.2 Algebra: Metric Measurements	99
24.3 Relate Customary and Metric	100
24.4 Appropriate Tools and Units	101
24.5 Problem Solving Skill: Estimate or Find Exact Answer	102

Chapter 25: Length and Perimeter	
25.2 Perimeter	103
25.3 Problem Solving Strategy: Draw a Diagram	104
25.5 Circumference	105

Chapter 26: Area	
26.1 Estimate and Find Area	106
26.2 Algebra: Areas of Parallelograms and Trapezoids	107

26.4 Algebra: Areas of Circles	108
26.5 Algebra: Surface Areas of Prisms and Pyramids	109

Chapter 27: Volume

27.1 Estimate and Find Volume	110
27.2 Problem Solving Strategy: Make a Model	111
27.3 Algebra: Volumes of Pyramids	112
27.5 Volumes of Cylinders	113

Unit 9: ALGEBRA: PATTERNS AND RELATIONSHIPS

Chapter 28: Patterns

28.1 Problem Solving Strategy: Find a Pattern	114
28.2 Patterns in Sequences	115
28.3 Number Patterns and Functions	116
28.4 Geometric Patterns	117

Chapter 29: Geometry and Motion

29.1 Transformations of Plane Figures	118
29.2 Tessellations	119
29.3 Problem Solving Strategy: Make a Model	120
29.4 Transformations of Solid Figures	121
29.5 Symmetry	122

Chapter 30: Graph Relationships

30.1 Inequalities on a Number Line	123
30.2 Graph on the Coordinate Plane	124
30.3 Graph Relations	125
30.4 Problem Solving Skill: Make Generalizations	126
30.6 Graph Transformations	127

Name _____

Estimate with Whole Numbers**Vocabulary**

- When both factors in a multiplication problem are rounded up to estimate the product, the estimate is an _____.
- When all addends are about the same, you can use _____ to estimate their sum.

Estimate the sum or difference.

$$\begin{array}{r} 3. \quad 2,489 \\ \quad 1,601 \\ +2,109 \\ \hline \end{array}$$

$$\begin{array}{r} 4. \quad 398 \\ \quad 415 \\ +368 \\ \hline \end{array}$$

$$\begin{array}{r} 5. \quad 4,723 \\ \quad +2,198 \\ \hline \end{array}$$

$$\begin{array}{r} 6. \quad 7,132 \\ \quad 6,594 \\ +7,301 \\ \hline \end{array}$$

$$\begin{array}{r} 7. \quad 5,401 \\ \quad +9,188 \\ \hline \end{array}$$

$$\begin{array}{r} 8. \quad 478 \\ \quad - 26 \\ \hline \end{array}$$

$$\begin{array}{r} 9. \quad 263 \\ \quad -211 \\ \hline \end{array}$$

$$\begin{array}{r} 10. \quad 5,877 \\ \quad -5,318 \\ \hline \end{array}$$

$$\begin{array}{r} 11. \quad 8,528 \\ \quad -6,491 \\ \hline \end{array}$$

$$\begin{array}{r} 12. \quad 8,903 \\ \quad -4,575 \\ \hline \end{array}$$

Estimate the product or quotient.

$$\begin{array}{r} 13. \quad 53 \\ \quad \times 8 \\ \hline \end{array}$$

$$\begin{array}{r} 14. \quad 76 \\ \quad \times 9 \\ \hline \end{array}$$

$$\begin{array}{r} 15. \quad 72 \\ \quad \times 28 \\ \hline \end{array}$$

$$\begin{array}{r} 16. \quad 47 \\ \quad \times 53 \\ \hline \end{array}$$

$$\begin{array}{r} 17. \quad 660 \\ \quad \times 42 \\ \hline \end{array}$$

$$\begin{array}{r} 18. \quad 371 \\ \quad \times 78 \\ \hline \end{array}$$

$$\begin{array}{r} 19. \quad 68 \\ \quad \times 37 \\ \hline \end{array}$$

$$\begin{array}{r} 20. \quad 480 \\ \quad \times 192 \\ \hline \end{array}$$

$$\begin{array}{r} 21. \quad 375 \\ \quad \times 591 \\ \hline \end{array}$$

$$\begin{array}{r} 22. \quad 824 \\ \quad \times 693 \\ \hline \end{array}$$

$$23. \quad 331 \div 5$$

$$24. \quad 643 \div 9$$

$$25. \quad 1,827 \div 59$$

$$26. \quad 5,543 \div 77$$

$$27. \quad 9,165 \div 28$$

$$28. \quad 6,281 \div 875$$

$$29. \quad 7,118 \div 614$$

$$30. \quad 8,215 \div 897$$

Mixed Review

Round to the nearest 1,000.

$$31. \quad 4,571$$

$$32. \quad 8,445$$

$$33. \quad 1,902$$

$$34. \quad 6,679$$

Find the product.

$$35. \quad 6 \times 6 \times 6$$

$$36. \quad 3 \times 3 \times 3 \times 3$$

$$37. \quad 4 \times 4 \times 4 \times 4$$

Use Multiplication and Division

Multiply or divide. Estimate to check.

1.
$$\begin{array}{r} 46 \\ \times 12 \\ \hline \end{array}$$

2.
$$\begin{array}{r} 230 \\ \times 15 \\ \hline \end{array}$$

3.
$$\begin{array}{r} 417 \\ \times 40 \\ \hline \end{array}$$

4.
$$\begin{array}{r} 2,515 \\ \times 52 \\ \hline \end{array}$$

5.
$$\begin{array}{r} 387 \\ \times 66 \\ \hline \end{array}$$

6.
$$\begin{array}{r} 217 \\ \times 154 \\ \hline \end{array}$$

7.
$$\begin{array}{r} 6,903 \\ \times 627 \\ \hline \end{array}$$

8.
$$\begin{array}{r} 582 \\ \times 316 \\ \hline \end{array}$$

9.
$$\begin{array}{r} 6,148 \\ \times 744 \\ \hline \end{array}$$

10.
$$\begin{array}{r} 8,132 \\ \times 915 \\ \hline \end{array}$$

11. $4\overline{)96}$

12. $9\overline{)423}$

13. $19\overline{)361}$

14. $7\overline{)756}$

15. $32\overline{)450}$

16. $12\overline{)1,740}$

17. $19\overline{)912}$

18. $22\overline{)5,412}$

19. $31\overline{)4,836}$

20. $17\overline{)5,865}$

Divide. Write the remainder as a fraction.

21. $6\overline{)45}$

22. $14\overline{)550}$

23. $18\overline{)459}$

24. $41\overline{)13,210}$

25. $55\overline{)33,125}$

Mixed Review

Estimate the sum, difference, product, or quotient.

Solve by using addition and subtraction.

30. $9,271 - 3,587 - 1,266 - 2,650$ _____

31. $2,114 + 739 + 4,799 + 557 + 1,632$ _____

Name _____

Problem-Solving Strategy: Predict and Test

Solve by predicting and testing.

1. Ryan bought a total of 40 juice boxes. He bought 8 more boxes of apple juice than of grape juice. How many of each kind did he buy?

2. The perimeter of a rectangular garden is 56 ft. The length is 4 ft more than the width. What are the dimensions of the garden?

3. The Hawks soccer team played a total of 24 games. They won 6 more games than they lost, and they tied 2 games. How many games did they win?

4. Rico collected a total of 47 rocks. He gathered 5 more jagged rocks than smooth rocks. How many of each kind of rock did he collect?

5. Matt has earned \$75. To buy a bicycle, he needs twice that amount plus \$30. How much does the bicycle cost?

6. The perimeter of a rectangular lot is 190 ft. The width of the lot is 15 ft more than the length. What are the dimensions of the lot?

7. The Wolverines swimming team won a total of 15 first- and second-place medals at their last swim meet. If they won 7 more first-place medals than second-place medals, how many first-place medals did they win?

8. Valley High School's football team played a total of 16 games. They won twice as many games as they lost. If they tied one game, how many games did the team win?

Mixed Review

Find the product or quotient. Estimate to check.

9. 306×582

10. $8,246 \div 38$

11. $21,420 \div 51$

Tell whether the estimate is an *overestimate* or *underestimate*. Then show how the estimate was determined.

12. $1,872 + 4,774 \approx 7,000$ _____

13. $321 \times 82 \approx 24,000$ _____

Name _____

Use Expressions

Vocabulary

Write the correct letter from Column 2.

Column 1

- _____ 1. a mathematical phrase that includes only numbers and operation symbols
- _____ 2. an expression that includes a variable
- _____ 3. a letter or symbol that stands for one or more numbers

Column 2

- a. numerical expression
- b. variable
- c. algebraic expression

Write a numerical or algebraic expression for the word expression.

4. seven less than eleven

5. six more than a number, x

6. 8 multiplied by m

7. 84 divided by 8

Evaluate each expression.

8. 19×48

9. $63b$, for $b = 15$

10. $w + 178$, for $w = 226$

11. $a \div b$, for $a = 253$
and $b = 11$

12. $h + k - 84$, for $h = 46$
and $k = 73$

13. $r(s)$, for $r = 109$
and $s = 33$

Mixed Review

Multiply or divide.

14. $18 \overline{)1,854}$

15. $\begin{array}{r} 631 \\ \times 55 \\ \hline \end{array}$

16. $\begin{array}{r} 490 \\ \times 117 \\ \hline \end{array}$

17. $54 \overline{)11,988}$

18. Use the table at the right. If the pattern continues, how many laps in all will 8 swimmers swim on the fourth day?

Each Swimmer's Training Schedule				
Day	1	2	3	4
Laps	6	8	10	<input type="checkbox"/>

Name _____

Mental Math and Equations

Determine which of the given values is a solution of the equation.

1. $4d = 28$;
 $d = 7, 8, \text{ or } 9$

2. $50 - t = 28$;
 $t = 20, 21, \text{ or } 22$

3. $42 \div n = 6$;
 $n = 5, 6, \text{ or } 7$

4. $72 + v = 85$;
 $v = 12, 13, \text{ or } 14$

5. $m + 7 = 18$;
 $m = 9, 10, \text{ or } 11$

6. $s - 17 = 10$;
 $s = 26, 27, \text{ or } 28$

7. $c \div 8 = 3$;
 $c = 22, 23, \text{ or } 24$

8. $155 = 5k$;
 $k = 30, 31, \text{ or } 32$

9. $8 = 25 - x$;
 $x = 17, 18, \text{ or } 19$

Solve each equation by using mental math.

10. $e + 6 = 20$

11. $x \div 2 = 10$

12. $6 \times h = 300$

13. $s - 18 = 40$

14. $92 = b + 7$

15. $90 \div t = 15$

16. $m - 150 = 420$

17. $8 \times n = 72$

18. $f - 6 = 98$

19. $c \times 4 = 40$

20. $63 = d \times 7$

21. $k + 28 = 32$

22. $9x = 180$

23. $6 = v - 58$

24. $w \div 9 = 12$

25. $p + 62 = 100$

Mixed Review

Find the sum or difference. Estimate to check.

26.
$$\begin{array}{r} 390 \\ + 789 \\ \hline \end{array}$$

27.
$$\begin{array}{r} 9,056 \\ - 1,732 \\ \hline \end{array}$$

28.
$$\begin{array}{r} 1,978 \\ + 693 \\ \hline \end{array}$$

29.
$$\begin{array}{r} 47,813 \\ - 9,507 \\ \hline \end{array}$$

30.
$$\begin{array}{r} 73,681 \\ + 50,342 \\ \hline \end{array}$$

Evaluate each expression.

31. $n + 701$, for
 $n = 510$

32. $50p$, for $p = 53$

33. $r \times s$, for $r = 12$
and $s = 30$

34. $h + g$, for $h = 65$
and $g = 41$

Name _____

Use the Properties**Vocabulary**

Write the correct letter from Column 2.

Column 1

- _____ 1. Associative Property
- _____ 2. Commutative Property
- _____ 3. compensation
- _____ 4. Distributive Property
- _____ 5. Identity Property of One

Column 2

- a. $58 + 72 = (58 + 2) + (72 - 2)$
- b. $3 \times (2 \times 4) = (3 \times 2) \times 4$
- c. $10 \times 23 = 23 \times 10$
- d. $18x = 18$
- e. $6 \times 24 = 6 \times (20 + 4)$

Use mental math to find the value.

- | | | |
|--------------------------|---|----------------------------------|
| 6. $37 + 14$ _____ | 7. $65 - 23$ _____ | 8. 18×6 _____ |
| 9. $258 \div 3$ _____ | 10. 18×22 _____ | 11. $141 \div 3$ _____ |
| 12. $78 - 45$ _____ | 13. $49 + 14$ _____ | 14. $41 + 18$ _____ |
| 15. 19×11 _____ | 16. $37 - 11$ _____ | 17. $366 \div 6$ _____ |
| 18. $320 \div 5$ _____ | 19. $59 + 26$ _____ | 20. $74 - 23$ _____ |
| 21. 15×51 _____ | 22. $88 - 54$ _____ | 23. 43×21 _____ |
| 24. $465 \div 15$ _____ | 25. $56 + 15$ _____ | 26. 15×48 _____ |
| 27. $32 + 35$ _____ | 28. $153 \div 9$ _____ | 29. $96 - 25$ _____ |
| 30. $37 + 14 + 43$ _____ | 31. $(7 \times 12) + (7 \times 18)$ _____ | 32. $5 \times 33 \times 6$ _____ |

Mixed ReviewEvaluate each expression for $a = 72$, $b = 28$, and $c = 8$.

- | | | | |
|------------------|-------------------|----------------|---------------|
| 33. $b \times 7$ | 34. $a + b + 362$ | 35. $a \div c$ | 36. $225 - a$ |
| _____ | _____ | _____ | _____ |

Solve each equation using mental math.

- | | | | |
|-----------------------|-------------------|----------------------|-------------------|
| 37. $n \times 8 = 56$ | 38. $19 + w = 36$ | 39. $h \div 20 = 35$ | 40. $98 - x = 59$ |
| _____ | _____ | _____ | _____ |

Name _____

Exponents

Vocabulary

Complete using *exponent* or *base*.

1. A(n) _____ shows how many times a number called the _____ is used as a factor.

Write the equal factors. Then find the value.

- | | | |
|----------|-----------|-----------|
| 2. 5^4 | 3. 10^5 | 4. 18^2 |
| _____ | _____ | _____ |
| 5. 2^6 | 6. 15^1 | 7. 4^3 |
| _____ | _____ | _____ |

Write in exponent form.

- | | | |
|--|-----------------------------------|--|
| 8. $1 \times 1 \times 1$ | 9. $n \times n \times n \times n$ | 10. $6 \times 6 \times 6 \times 6 \times 6$ |
| _____ | _____ | _____ |
| 11. $10 \times 10 \times 10 \times 10$ | 12. $y \times y$ | 13. $4 \times 4 \times 4 \times 4 \times 4 \times 4$ |
| _____ | _____ | _____ |

Express with an exponent and the given base.

- | | | |
|-----------------|-----------------|------------------------|
| 14. 125, base 5 | 15. 256, base 4 | 16. 729, base 9 |
| _____ | _____ | _____ |
| 17. 64, base 2 | 18. 81, base 3 | 19. 1,000,000, base 10 |
| _____ | _____ | _____ |

Mixed Review

Use mental math to find the value.

- | | | |
|---------------|------------------------------------|-----------------------------------|
| 20. $65 + 27$ | 21. $20 \times 14 \times 5$ | 22. $(9 \times 4) + (9 \times 6)$ |
| _____ | _____ | _____ |
| 23. $84 - 45$ | 24. $3 \times 3 \times 3 \times 3$ | 25. 7^2 |
| _____ | _____ | _____ |

Name _____

Order of Operations

Give the correct order of operations.

1. $100 + 6^2 - 9$

2. $(52 - 49)^2 \div 9$

3. $(5^2 + 1) \div 2$

4. $(9 + 2) \times (16 - 12)^2$

Evaluate the expression.

5. $27 \div 3 + 1$

6. $(6 + 8) \times (9 - 8)$

7. $(6 + 7^2) \div 5 \times 2$

8. $(12 \div 2)^3 + (2^3 + 1^3)$

9. $(15 - 5)^2 - (4 \times 3)$

10. $(57 + 3) \times 2^4$

11. $(19 + 9) \div (2^3 - 1) + 20$

12. $(3 \times 7^2) - (5^3 - 9^2) + 10^2$

13. $3 \times (10^2 - 65) + (5^2 \times 2)$

Evaluate the expression for $s = 5$ and $t = 12$.

14. $50 \div s + 7$

15. $s^2 + 150$

16. $2 \times t - 18$

17. $t^2 - 3 \times 8$

18. $15 + t \div 6$

19. $27 + 9 \times s$

Mixed Review

Use mental math to find the value.

20. 12×7

21. $37 + 62$

22. $434 \div 7$

23. $1,731 - 605$

Write in exponent form.

24. $8 \times 8 \times 8 \times 8$

25. $6 \times 6 \times 6 \times 6 \times 6$

26. $n \times n \times n \times n \times n$

Name _____

Problem-Solving Skill

Sequence and Prioritize the Information

Tiffany and her dad need to make brownies for the PTA bake sale. They need to deliver the brownies to the school by 1 P.M. To plan their morning, they made a list of the things they need to do, including a time estimate for each task.

To Do List
<ul style="list-style-type: none"> • Bake brownies, 20 minutes. • Let brownies cool, 20 minutes. • Grocery shopping, buy brownie ingredients, 1 hour. • Drive to the school, 10 minutes. • Mix brownies, 30 minutes. • Wrap brownies separately in plastic wrap, 15 minutes.

1. List the items in the To Do List in an order that makes sense.

2. Can they get everything done if they begin at noon? Explain

Alex has several things to do on Saturday.

3. List his activities in an order that makes sense.

Saturday Activities
<ul style="list-style-type: none"> • Attend birthday party at 4 P.M. • Buy gift—either a CD for \$16 or a computer game for \$25. • Get haircut at 2 P.M.; cost \$9. • Before 10 A.M., mow Mrs Brown’s lawn; earn \$15. • Mow Mr. Tanaka’s lawn after 10:00 A.M. earn \$15. Trim hedge, earn \$10. • Set aside \$5 for savings. • Keep \$5 for spending money.

4. Which gift can Alex buy? Why? Assume he has no spending money left from last week.

Mixed Review

Evaluate each expression.

5. $t \times 7$, for $t = 25$

6. $150 - h$, for $h = 88$

7. $96 \div r$, for $r = 2$

Name _____

Represent, Compare, and Order Decimals

Write the value of the underlined digit.

1. 485.036

2. 16,005.845

3. 8,492.7792

Write the number in expanded form.

4. 5.71 _____

5. 85.083 _____

6. 0.4625 _____

7. 17.00157 _____

Compare the numbers. Write $<$, $>$, or $=$ for \bigcirc .

8. $15.4 \bigcirc 14.5$ _____

9. $5.67 \bigcirc 5.76$ _____

10. $43.90 \bigcirc 43.9$ _____

11. $7.91 \bigcirc 9.17$ _____

12. $765.28 \bigcirc 762.58$ _____

13. $0.234 \bigcirc 2.304$ _____

Write the numbers in order from least to greatest.

14. 3,224; 2,432; 3,422

15. 88.5; 85.8; 58.8

16. 6.21; 6.02; 6.12

Write the numbers in order from greatest to least

17. 0.005; 0.500; 0.050

18. 317.8; 318.7; 371.8

19. 16.04; 14.6; 16.4

Mixed Review

Evaluate each expression.

20. $4 + 3^3 \times 2 - (6 - 1)$

21. $(11 + 16) \div 3 + (4 - 2)^2$

22. $45 + (6^2 - 11) \times 2$

Solve each equation using mental math.

23. $m - 7 = 36$

24. $9x = 63$

25. $a \div 6 = 14$

Evaluate each expression for $a = 6$, $b = 120$, and $c = 54$.

26. $b + 295$

27. $93 - c$

28. $b \div a$

Name _____

Problem Solving Strategy: Make a Table

Solve the problem by making a table.

1. Earthquakes are measured using the Richter scale. The greater the number, the greater the strength (or magnitude). Some of the strongest earthquakes during the twentieth century had magnitudes of 7.2, 8.9, 8.4, 8.7, 8.3, 8.6, 7.7, and 8.1. The San Francisco earthquake of 1906 had the fifth highest magnitude of those given above. What was its magnitude on the Richter scale?

3. Danny is doing research on animals at the library. He has spent 25 minutes reading about insects. He thinks he will need the same amount of time for each of 5 other types of animals. If he began at 9:45 A.M., at what time would he finish?

2. Late in 1999, one U.S. dollar was worth the following amounts in five other countries' money.

Australian dollar	1.5798
Brazilian real	1.8780
Canadian dollar	1.4796
German mark	1.9524
Swiss franc	1.5919

In which country could one U.S. dollar be exchanged for the greatest amount of that country's money?

4. A theater is showing two films. The starting times for the first film are every even hour, beginning at noon. The starting times for the second film are every odd hour, beginning at 1:00 P.M. If the last show begins at 10:00 P.M., how many times are both films shown?

Use the table at the right for 5 and 6. The data shows the amount of energy in quadrillion BTUs.

5. In which country is the difference between the amount of energy produced and amount used the greatest?

Country	Energy Produced	Energy Used
United States	66.68	82.19
Great Britain	9.23	9.68
China	30.18	29.22
Canada	14.36	10.97
India	6.94	8.51
Russia	45.66	32.72

6. In which country is the difference between the amount of energy produced and amount used the least? _____

Mixed Review

Add or subtract mentally.

7. $67 + 83 + 33$

8. $449 - 398$

9. $203 + 178 + 22$

Tell which operation you would do first.

10. $8 - 5 + 7$

11. $16 + 4 \div 2$

12. $(10 + 4) \times 2$

Name _____

Estimate with Decimals

Estimate.

1. $3.8 + 7.9$

2. 7.1×6.2

3. $23.18 - 19.09$

4. $12.2 \div 5.9$

5. 4.09×6.18

6. $83.89 + 17.66$

7. $162.3 \div 15.7$

8. $31.6 - 8.82$

9. $7.7 + 118.2$

10. $101.2 - 34.9$

11. $\$35.99 - \6.02

12. 19.8×21.3

13. $\$124.66 \times 3$

14. $10.6 + 19.01$

15. 81.3×9.6

16. $810.1 - 69.9$

17. $602.5 + 87.3$

18. 397.9×21

19. $502.03 \div 4.9$

20. $\$88.20 + \79.10

21. $1.8 + 2.9 + 11.8$

22. $\$203.99 \div 21$

23. $\$199.50 - \53.99

24. 8.8×7.1

25. $67.2 + 11.9 + 107.44$

26. $889.52 - 402.68$

Mixed Review

Write in exponent form.

27. $4 \times 4 \times 4$

28. $2 \times 2 \times 2 \times 2$

29. 6×6

30. $1 \times 1 \times 1 \times 1 \times 1$

31. $7 \times 7 \times 7 \times 7$

32. $8 \times 8 \times 8$

33. $9 \times 9 \times 9$

34. $3 \times 3 \times 3 \times 3$

Find the value.

35. 5^2

36. 2^5

37. 8^2

38. 1^4

Name _____

Decimals and Percents

Write the decimal and percent for the shaded part.

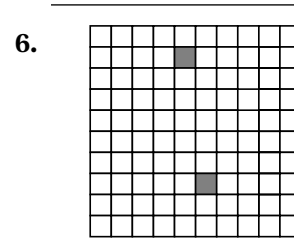
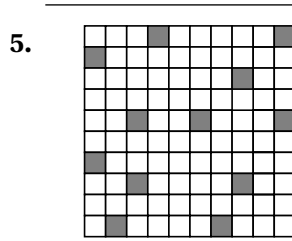
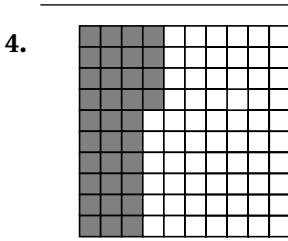
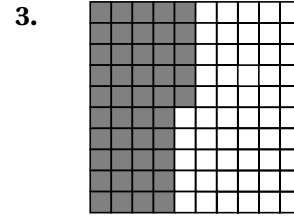
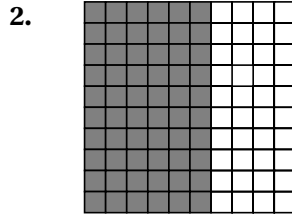
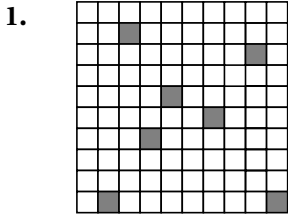

Write the percent or decimal.

7. 67%

8. 0.15

9. 0.92

10. 11%

11. 80%

12. 0.3

13. 64%

14. 88%

15. 0.14

16. 90%

17. 0.09

18. 34%

19. 0.75

20. 6%

21. 0.19

Mixed Review

Evaluate the expression.

22. $6 + 3 \times 2$

23. $10 \div 2 - 1$

24. $16 - 4 \times 2$

25. $20 \times 2 + 1$

26. $(8 - 2) \times 3$

27. $15 \div 3 + 2$

28. $32 + 8 \div 2$

29. $20 + (6 \times 2)$

30. $45 \div (4 + 5)$

31. $(16 - 7)^2 \div 3$

32. $6^2 + 14 \div 2$

33. $12 \times (9 - 4)$

Name _____

Add and Subtract Decimals

Add or subtract. Estimate to check.

1. $0.34 + 8.19$

2. $6.92 + 3.55$

3. $0.418 + 1.291$

4. $8.93 + 2.68$

5. $8.7 - 4.2$

6. $13.29 - 5.96$

7. $5.41 - 1.36$

8. $15.93 - 7.08$

9. $9.328 + 1.294$

10. $5.962 - 1.748$

11. $4.036 - 2.751$

12. $4.89 + 12.45$

13. $8.116 - 3.094$

14. $23.4 - 12.379$

15. $20.68 + 7.12$

16. $1.681 + 2.899$

17. $41.783 - 29.822$

18. $21.35 + 37.7 + 12.816$

19. $\$245.62 - \109.99

20. $41.6 + 27.56 + 16.942$

21. $452.803 - 376.991$

22. $111.22 + 77.5 + 83.947$

$$\begin{array}{r} 23. \quad 446.09 \\ \quad 811.36 \\ + \quad 73.52 \\ \hline \end{array}$$

$$\begin{array}{r} 24. \quad 8.71 \\ \quad 13.99 \\ + \quad 67.2 \\ \hline \end{array}$$

$$\begin{array}{r} 25. \quad 89.01 \\ \quad - 67.56 \\ \hline \end{array}$$

$$\begin{array}{r} 26. \quad 25.8 \\ \quad - 17.226 \\ \hline \end{array}$$

Mixed Review

Write the numbers in order from greatest to least.

31. 21.10; 21.050; 21.8

32. 36.63; 36.33; 36.36

33. 5.912; 5.921; 5.192

Write the percent or decimal.

34. 0.98

35. 73%

36. 44%

37. 0.06

38. 90%

Name _____

Multiply Decimals

Tell the number of decimal places there will be in the product.

1. 6.3×0.75

2. 9.7×48.8

3. 5.96×62.15

4. 37.6×8.3

5. 32.08×7.3

6. 428.9×5.6

7. 897.3×5.3

8. 186.472×9.6

Place the decimal point in the product.

9. $6.17 \times 8.2 = 50594$

10. $24.01 \times 8.51 = 2043251$

11. $8.94 \times 5.27 = 471138$

12. $8.04 \times 1.7 = 13668$

13. $19.6 \times 5.8 = 11368$

14. $30.7 \times 8.33 = 255731$

Multiply. Estimate to check.

15. 5×0.9

16. 9×1.2

17. 4×3.47

18. $\$18.93 \times 7$

19. 5.55×9

20. 5×2.89

21. 31.82×4

22. 4.61×8

23. 2.49×6

24. 35.98×6.3

25. 73.02×9.1

26. 8.5×16.03

27. 3.91×6.22

28. 164.5×0.03

29. 28.14×1.52

30. 6.114×3.72

Mixed Review

Write the decimal and the percent for the shaded part.

31.

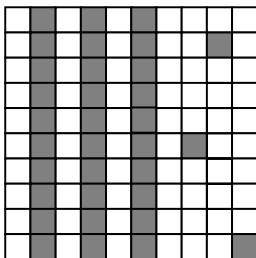

32.

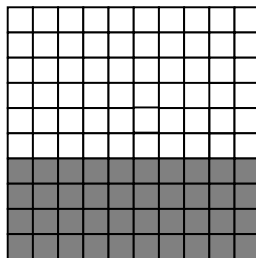

33.

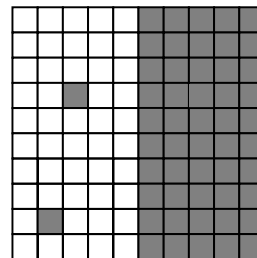

Name _____

Divide with Decimals

Rewrite the problem so that the divisor is a whole number.

1. $8.5 \div 2.3$

2. $6.4 \div 1.3$

3. $9.1 \div 0.15$

4. $33.17 \div 6.8$

Place the decimal point in the quotient.

5. $7.48 \div 0.25 = 2992$

6. $116.13 \div 4.2 = 2765$

7. $56.68 \div 0.08 = 7085$

Divide. Estimate to check.

8. $36.9 \div 3$

9. $22.4 \div 7$

10. $37.5 \div 5$

11. $89.6 \div 8$

12. $14 \overline{)78.4}$

13. $40 \overline{)6.8}$

14. $13 \overline{)150.8}$

15. $70 \overline{)23.8}$

16. $5.32 \div 0.7$

17. $1.88 \div 0.4$

18. $2.12 \div 0.2$

19. $5.4 \div 0.08$

20. $7.54 \overline{)24.882}$

21. $12.6 \overline{)806.4}$

22. $0.91 \overline{)6.734}$

23. $10.9 \overline{)81.75}$

24. $2.9 \overline{)0.3335}$

25. $0.18 \overline{)64.296}$

26. $12.3 \overline{)84.87}$

27. $8.7 \overline{)53.244}$

Mixed Review

Add, subtract, or multiply.

28.
$$\begin{array}{r} 78.94 \\ 9.66 \\ + 103.71 \\ \hline \end{array}$$

29.
$$\begin{array}{r} 1,083.75 \\ - 706.9 \\ \hline \end{array}$$

30.
$$\begin{array}{r} 0.072 \\ \times 0.48 \\ \hline \end{array}$$

31. $215.6 + 49.87 + 8.351$

32. 42.83×1.91

33. $65.85 - 39.478$

34. $430.62 - 288.74$

35. $192.6 + 847.56$

36. 17.335×8.26

Name _____

Problem-Solving Skill: Interpret the Remainder

Solve the problem by interpreting the remainder.

- | | |
|--|---|
| <p>1. Thirty-seven people are attending a party at a restaurant. In the banquet room, the restaurant staff has set up tables that can each seat 8 people. What is the least number of tables that the group will use?</p> <p>_____</p> | <p>2. There are 23 pancakes on the griddle at a restaurant. The chef places 4 pancakes on each order. How many orders can the chef fill, and how many pancakes must be added to those remaining to make another order?</p> <p>_____</p> |
| <p>3. A library reading room contains a number of tables that can seat 4 people. What is the least number of tables needed to seat 54 people?</p> <p>_____</p> | <p>4. A group of 5 friends wants to buy snacks. If each snack costs \$0.75 and they have a total of \$4.80 to spend, how many snacks can they buy?</p> <p>_____</p> |
| <p>5. The chef at a restaurant uses 3 eggs to make each omelet. If the chef has 200 eggs, how many 3-egg omelets can he make?</p> <p>_____</p> | <p>6. A total of 125 hamburgers were sold at a fund-raiser at the last football game. If the hamburger patties came in packages of 8, how many packages were opened?</p> <p>_____</p> |

Mixed Review

Estimate the sum or difference.

$$\begin{array}{r} 7. \quad 671 \\ +902 \\ \hline \end{array}$$

$$\begin{array}{r} 8. \quad 478 \\ -310 \\ \hline \end{array}$$

$$\begin{array}{r} 9. \quad 831 \\ -289 \\ \hline \end{array}$$

$$\begin{array}{r} 10. \quad 1,226 \\ +533 \\ \hline \end{array}$$

$$\begin{array}{r} 11. \quad 661 \\ +2,403 \\ \hline \end{array}$$

$$\begin{array}{r} 12. \quad 1,729 \\ -494 \\ \hline \end{array}$$

$$\begin{array}{r} 13. \quad 488 \\ -391 \\ \hline \end{array}$$

$$\begin{array}{r} 14. \quad 2,994 \\ +1,258 \\ \hline \end{array}$$

Solve each equation by using mental math.

15. $m + 12 = 15$

16. $5 \times w = 20$

17. $x - 7 = 8$

18. $q + 4 = 10 + 6$

19. $6 \times r = 24$

20. $y - 9 = 10$

21. $a - 2 = 8 + 6$

22. $d + 3 = 21 - 7$

Name _____

Decimal Expressions and Equations

Evaluate each expression.

1. $t - 1.2$ for $t = 3$

2. $y + 4.6$ for $y = 2.4$

3. $8.2 - m$ for $m = 1.1$

4. $2.4 \div a$ for $a = 6$

5. $6g$ for $g = 1.5$

6. $j - 6.3$ for $j = 9.6$

7. $12.6 + r$ for $r = 4.4$

8. $4.5 \div p$ for $p = 9$

9. $7.24 - q$ for $q = 1.04$

10. $6.18 \div y$ for $y = 3$

11. $t + 4.66$ for $t = 2.1$

12. $5h$ for $h = 2.4$

Solve each equation by using mental math.

13. $w + 4.5 = 8$

14. $\frac{k}{3} = 2.5$

15. $1.4 = \frac{t}{2}$

16. $m - 7.6 = 2.4$

17. $3a = 6.9$

18. $9c = 22.5$

19. $3b = 6.4 + 2.6$

20. $w + 10.3 = 21.7$

21. $13.7 = d - 3.4$

22. $4.8 = \frac{n}{4}$

23. $\frac{x}{5} = 19.5$

24. $7h = 15.4$

Mixed Review

Estimate.

25. $6.9 + 7.8$

26. 31.77×6

27. $63.85 \div 8$

28. $17.04 - 9.8$

29. $18.58 + 21.44$

30. 91.92×4

31. $54.3 - 19.7$

32. $80.8 \div 9.2$

Find the quotient.

33. $88.8 \div 6$

34. $59.4 \div 36$

35. $38.88 \div 7.2$

36. $31.108 \div 2.2$

Name _____

Samples

Determine the type of sample. Write *convenience*, *random*, or *systematic*.

1. An assembly-line worker randomly selected one microwave oven and then checked every fifteenth oven to see whether it worked.

2. Carl selected students to complete a survey by assigning each student's name a number from 1 to 6, rolling a cube numbered 1 to 6, and choosing each student whose name had the number he rolled.

3. A store manager asked the first 50 shoppers to enter her store on Saturday to complete a survey about changes they would like to see made at the store.

Tell whether you would survey the population or use a sample. Explain.

4. You want to know the type of computer, if any, that each student in your class has at home.

5. You want to know the average number of siblings of all sixth grade students in your school district.

6. You want to know your friends' favorite television.

Mixed Review

Evaluate each expression.

- | | | |
|---------------------------------------|---------------------------------------|--|
| 7. $9.03 \div x$ for $x = 3$
_____ | 8. $7m$ for $m = 2.2$
_____ | 9. $4.5 - w$ for $w = 1.9$
_____ |
| 10. $17.4 + h$ for $h = 5.9$
_____ | 11. $k \div 2$ for $k = 6.4$
_____ | 12. $6.58 + a$ for $a = 0.45$
_____ |

Name _____

Bias in Surveys**Vocabulary**

Complete.

1. A sample is _____ if individuals in the population are not represented in the sample.

Tell whether the sampling method is *biased* or *unbiased*. Explain.

The Tri-State Soccer League is conducting a survey to determine if the players want to change the style of soccer shirt.

2. Randomly survey all players who wear size large shirts. 3. Randomly survey all members of championship teams.

4. Randomly survey 80 players. 5. Randomly survey all league coaches.

Determine whether the question is biased. Write *biased* or *unbiased*.

6. Do you feel that country music is better than all other types of music? 7. What type of team sport do you enjoy playing?

Mixed Review

Solve each equation by using mental math.

8. $w - 7.5 = 12.3$

9. $5x = 16.5$

10. $a + 6.9 = 14.3$

Find the quotient.

11. $22.78 \div 6.7$

12. $49.6 \div 8$

13. $20.37 \div 3.5$

Solve .

14. Kyle rode his bicycle a total of 48 kilometers at a rate of 8 kilometers per hour. How long did he ride?

15. Joanne earns \$24.50 per hour as a construction worker. How much does she earn if she works 7.5 hours?

Name _____

Problem Solving Strategy: Make a Table

Solve the problem by displaying the data in a table.

During the basketball season, the Falcons scored the following numbers of points in their games: 63, 52, 47, 51, 60, 49, 48, 54, 71, 52, 40, 38, 57, 46, 44, 63, 70

- 1. How many rows of data are in your table?
- 2. How many scores are greater than 40 but less than 61?

- 3. The Falcons won every game in which they scored more than 60 points. How many games did they play in which they scored more than 60 points?
- 4. The team lost every game in which they did not score more than 40 points. How many games did they play in which they did not score more than 40 points?

- 5. The Falcons' record for the season was 11 wins and 7 losses. How many games did they win in which they scored 60 points or fewer?
- 6. With a record of 11 wins and 7 losses, how many games did the Falcons lose when they scored more than 40 points?

Solve.

- 7. Dennis has 5 friends and wants to invite 2 of them to go to a baseball game with him and his family. How many different choices of 2 friends can Dennis make?
- 8. Latifah has a project that is due on May 15. She expects the project to take her 3 weeks to complete. What is the latest date on which she could begin her project in order to be done on time?

Mixed Review

Write the percent or decimal.

- 9. 16%
- 10. 5%
- 11. 0.55
- 12. 0.83
- 13. 0.07

Name _____

Frequency Tables and Line Plots

Vocabulary

1. A running total of the number of people surveyed is called a
_____.
2. A _____ shows the total for each category or group in a set of data.

For 3–4, use the data in the chart at the right.

Students' Heights (cm)					
160	137	158	155	136	154
154	159	142	147	148	144
152	133	135	136	162	158
139	160	154	139	159	144
155	147	136	148	162	133

3. Find the range. _____
4. Make a line plot

For 5–6, use the chart at the right.

Reading Test Scores				
98	100	81	92	78
75	96	78	84	100
82	100	100	86	78

5. Find the range. _____
6. Make a line plot

Mixed Review

Compare the numbers. Write $>$, $<$, or $=$ for \bigcirc .

7. $31.7 \bigcirc 37.1$ _____
8. $72.67 \bigcirc 72.670$ _____
9. $66.61 \bigcirc 66.16$ _____

Solve. Use the information in the table.

**Population of the Four Largest
Cities in Montana in 1999**

City	Population
Billings	91,195
Great Falls	57,758
Missoula	51,204
Butte-Silver Bow	34,051

10. Estimate the combined population of the four cities. _____
11. How many more people lived in Billings than in Missoula. _____

Name _____

Measures of Central Tendency

Vocabulary

Write the correct letter from Column 2.

Column 1

Column 2

- _____ 1. mean a. number that appears most often in a group of numbers
- _____ 2. median b. sum of a group of numbers divided by the number of addends
- _____ 3. mode c. middle number in a group of numbers arranged numerically

Complete the table.

	Data	Mean	Median	Mode
4.	12, 15, 11, 15, 13, 10, 15			
5.	68, 74, 71, 69, 74, 78, 70			
6.	7.6, 6.2, 6.0, 6.2, 8.1, 6.7			
7.	168, 212, 146, 195, 200, 156			

For 8–10, use the table below.

Test	1	2	3	4	5	6
Score	91	84	96	89	93	84

- 8. Find the mean. _____
- 9. Find the median. _____
- 10. Find the mode. _____

Test Scores									
98	88	82	91	83	76	98	100	84	90

- 11. Use the data above to make a line plot. Use your line plot to find the median and mode.

Mixed Review

Write the numbers in order from least to greatest.

- 12. 218.4, 284.1, 241.8, 214.8
- 13. 6.17, 6.71, 6.107, 6.701

Name _____

Outliers and Additional Data

Use the following data for 1–2.

The first 6 packages that were checked in at an airline ticket counter when it opened for business weighed 15 pounds, 21 pounds, 19 pounds, 14 pounds, 18 pounds, and 15 pounds.

1. Find the mean, median, and mode of the weights of the first 6 packages that were checked in at the counter.
2. The next package checked in weighed 66 pounds. Find the mean, median, and mode of the weights of the 7 packages.

-
3. Some friends in the school chorus compared the number of siblings they had. Two had 3 siblings, three had 2 siblings, 6 had one sibling, and 1 had no siblings. What were the mean, median, and mode number of siblings for the group of friends?

-
4. Refer to Exercise 3. Suppose another student who has 9 siblings joins the discussion. Of the three measures of central tendency (mean, median, and mode), which measure is affected the most by including the new data value of 9 siblings?
-

Use the following data for 5–6.

A survey of stores found the following prices for a popular type of backpack: \$17, \$19, \$21, \$21, \$20, \$18, and \$24.

5. What were the mean, median, and mode of the prices for the backpack that were found during the survey?
6. One of the stores charging \$21 reduced its price to \$14 for one day. What are the new mean, median, and mode?

Mixed Review

Add or subtract.

$$\begin{array}{r} 7. \quad 6.8 \\ + 7.9 \\ \hline \end{array}$$

$$\begin{array}{r} 8. \quad 7.03 \\ + 3.89 \\ \hline \end{array}$$

$$\begin{array}{r} 9. \quad 15.4 \\ - 6.7 \\ \hline \end{array}$$

$$\begin{array}{r} 10. \quad 45.04 \\ - 27.5 \\ \hline \end{array}$$

Estimate.

15. 19.8×6.3

16. $51.2 - 19.9$

17. $8.9 + 24.2 + 16.7$

Name _____

Data and Conclusions

Write *yes* or *no* to tell whether the conclusion is valid.
Explain your answer.

1. A random sample of 100 middle school students were asked whether they think speed limits should be increased. Almost all of them believed that they should be. You conclude that drivers in general want higher speed limits.

2. At the music store where you buy CDs, the most popular type of music is rhythm and blues. You tell your friends that rhythm and blues must be the most popular type of music in the country.

3. Your teacher tells you that in your class of 24 students, there are 2 student birthdays each month. You decide that in the entire school, student birthdays are distributed evenly throughout the year.

4. You ask the first 60 students in line at the student cafeteria how they come to school. All but 15 students say they ride a school bus. You conclude that most students come to school by bus.

Mixed Review

Find the value.

- 5. $5 + 5 \times 4$ _____
- 6. $6 + (4 \times 3)$ _____
- 7. $20 \div 2 + 8$ _____
- 8. $(14 - 6) \times 2$ _____
- 9. $35 \div (15 - 8)$ _____
- 10. $10 + (8 \times 3)$ _____

Find the mean, median, and mode.

- 11. 412, 387, 297, 343
- 12. 11, 14, 19, 14, 17, 16, 7
- 13. 6.7, 6.7, 7.6, 4.2, 7.6

Name _____

Make and Analyze Graphs

Tell if you would use a bar, line, or circle graph to display the data.

1. The amount of time you spend in your classes in one day.

2. The amount of money you spend in two weeks.

3. The number of students who play different musical instruments.

4. The weights of 8 different pets.

5. Make a multiple-bar graph of the homework data below.
6. Make a multiple-line graph of the temperature data below.

Hours Spent Doing Homework

Name	Science	Math
Nigel	2.5 hr	0.5 hr
Marty	1 hr	1.5 hr
Julie	0.75 hr	2 hr
Luis	1.25 hr	1 hr



Average Low Temperature

Year	Jan	Feb	Mar
1998	-4°F	5°F	8°F
1999	6°F	3°F	12°F
2000	-10°F	9°F	16°F
2001	12°F	-5°F	14°F



7. Gretchen researched the number of new students who came to her school during 5 months of the school years 2000 and 2001. Her data are shown at the right. What kind of graph would you use to display the data? Explain.

Number of New Students

	Sept	Oct	Jan	Feb	Mar
2000	35	12	10	6	9
2001	5	23	14	0	12

Mixed Review

Estimate.

8. $71.3 + 68.6 + 69.7$

9. $284.17 \div 7.24$

10. 979.88×31.05

Name _____

Find Unknown Values

Sarina kept a record of her after-school earnings.

Number of Weeks Worked	1	2	3	4
Total Saved	\$14	\$28	\$42	\$56



- Use the data in the table to make a line graph. Use the line graph to estimate how much Sarina will have saved after working for 5 weeks.

- Use logical reasoning and arithmetic to find how much Sarina will have saved after working for 5 weeks. _____
- Use the line graph to estimate how many weeks Sarina will need to work in order to save \$98. _____
- Use logical reasoning and arithmetic to find how many weeks Sarina will have to work to save \$98. _____

A train averages 60 mi per hr while traveling between New York City and Chicago.

Time (hr)	1	2	3	4
Distance (mi)	60	120	180	240



- Use the data in the table to make a line graph. Use the line graph to estimate how long it will take the train to travel 360 mi.

- Use logical reasoning and arithmetic to find how long it will take the train to travel 360 mi. _____
- Use the formula $d = rt$ to find how long it will take the train to travel 480 mi. _____

Mixed Review

Use mental math to find the value.

8. $59 + 16$ _____ 9. $63 - 21$ _____ 10. $89 - 54$ _____

Compare the numbers. Write $<$, $>$, or $=$.

11. $0.547 \bigcirc 0.574$ _____ 12. $3.61 \bigcirc 3.16$ _____ 13. $68.90 \bigcirc 68.9$ _____

Name _____

Stem-and-Leaf Plots and Histograms

Tell whether a bar graph or a histogram is more appropriate.

- | | | |
|---|--|--|
| 1. frequency of fish caught at different times of day | 2. average monthly telephone bill for a year | 3. number of shoppers in a store during 3 different time intervals |
|---|--|--|

Make a stem-and-leaf plot of each set of data.

- | | |
|--|---|
| 4. Janet's math test scores:
95, 83, 78, 91, 75, 85, 91, 98, 80 | 5. Raoul's golf scores:
79, 85, 82, 86, 90, 94, 83, 85, 79, 91 |
|--|---|

For 6–7, use the table below.

Campers at Day Camp				
Age	5–7	8–10	11–13	14–16
Number	6	11	18	9

6. Make a histogram.
7. How would the number of campers in each group change if you used 5 groups instead of 4 groups?

For 8–9, use the histogram at the right.

8. During which time period did the most flights arrive?
- _____
9. How many flights arrived after 11:00?
- _____

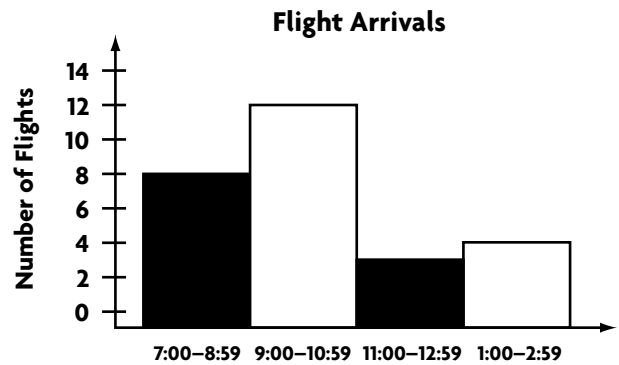
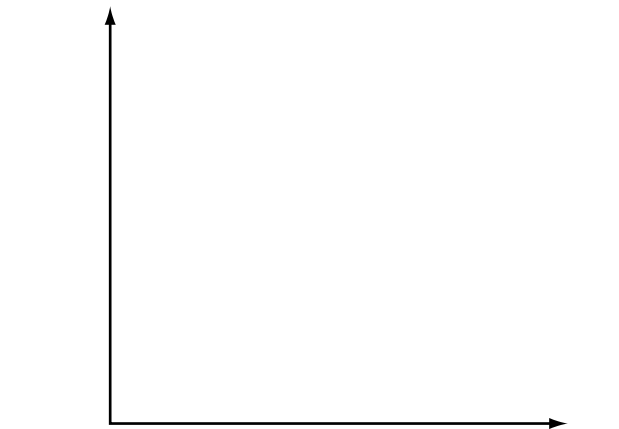

Mixed Review

- | | |
|---|--|
| 10. Bill has 180 baseball cards. He has 3 times as many infielders as outfielders. How many of each does he have? | 11. Tim gave a clerk \$20.00 for a book and received \$3.85 in change. How much did the book cost? |
|---|--|

Box-and-Whisker Graphs

For Exercises 1–3, use the box-and-whisker graph below.

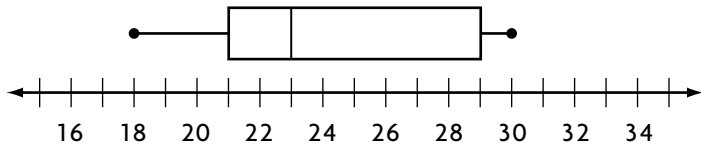

1. What is the median? _____
2. What are the lower and upper quartiles? _____
3. What are the lower and upper extremes and the range? _____

For Exercises 4–8, use the data in the chart below.

Lengths of Phone Calls (in min)									
17	21	16	22	24	26	18	28	25	29
21	18	14	23	25	18	26	24	22	23

4. What is the median? _____
5. What are the lower and upper quartiles? _____
6. What are the lower and upper extremes and the range? _____
7. Make a box-and-whisker graph.
8. What fractional part of the data is less than 25 minutes? _____

Mixed Review

For 9–10, use the data in the chart above for 4–8.

9. Complete the cumulative frequency table below for the data.
10. Make a line plot for the data.

Lengths of Phone Calls		
Minutes	Frequency	Cumulative Frequency
11–15		
16–20		
21–25		
26–30		

Name _____

Analyze Graphs

Renee asked each student in her math class the following question: “Would you rather have some great vanilla ice cream or would you prefer chocolate or strawberry?”

For 1–2, use the graph at the right, which shows the results of her survey.

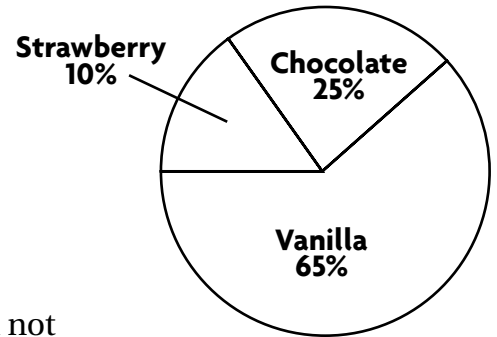

1. Could the way Renee asked the question have influenced her classmates’ answers? Explain.

2. Tell how you could rewrite the question so it would not influence the results of the survey.

A television network used the graph at the right to try to convince viewers that one of its shows, Show A, was far more popular than one of its competitor’s shows, Show B, which airs at the same time.

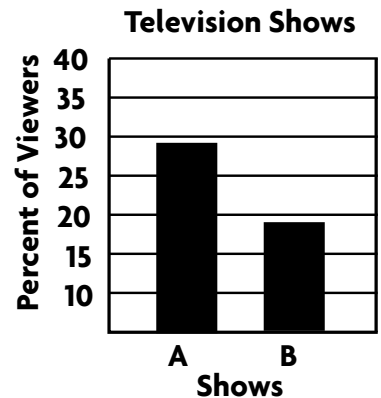

3. About how many times as high is the bar for Show A than for Show B?

4. Does twice the percent of the viewing audience watch Show A as watches Show B? _____
5. How can you change the graph so that it is not misleading?

Mixed Review

During one day at an airport, an airline experienced flight delays of the following number of minutes: 5, 7, 5, 10, 15, 15, 20, 91

6. Find the mean length of all the flight delays. _____
7. Find the mean of the delays if the outlier is not included. _____

Evaluate each expression.

8. $g + 1.7$ for $g = 3.3$ _____
9. $5y$ for $y = 1.8$ _____
10. $p - 4.9$ for $p = 11$ _____

Name _____

Divisibility

Tell whether each number is divisible by 2, 3, 4, 5, 6, 8, 9 or 10.

- | | | | |
|---------------------|---------------------|--------------------|---------------------|
| 1. 30
_____ | 2. 24
_____ | 3. 115
_____ | 4. 240
_____ |
| 5. 486
_____ | 6. 235
_____ | 7. 279
_____ | 8. 801
_____ |
| 9. 145
_____ | 10. 650
_____ | 11. 736
_____ | 12. 1,200
_____ |
| 13. 207
_____ | 14. 723
_____ | 15. 2,344
_____ | 16. 868
_____ |
| 17. 694
_____ | 18. 4,464
_____ | 19. 3,894
_____ | 20. 306
_____ |
| 21. 836
_____ | 22. 5,962
_____ | 23. 2,388
_____ | 24. 792
_____ |
| 25. 14,730
_____ | 26. 24,456
_____ | 27. 7,677
_____ | 28. 34,248
_____ |

For 29–31 write *T* or *F* to tell whether each statement is true or false.
If it is false, give an example.

29. No odd number is divisible by 2. _____
30. All numbers that are divisible by 4 are also divisible by 2. _____
31. All numbers that are divisible by 3 are also divisible by 6. _____
32. A number is between 40 and 50 and is divisible by both 3 and 4.

What is the number? _____

Mixed Review

Add or subtract mentally.

- | | | |
|-------------------------|--------------------------|------------------------------|
| 33. $451 - 71$
_____ | 34. $898 - 196$
_____ | 35. $109 + 46 + 54$
_____ |
|-------------------------|--------------------------|------------------------------|

Name _____

Prime Factorization**Vocabulary**

1. Write *true* or *false*. Prime factorization renames a composite number as the product of prime factors. _____
-

Use division or a factor tree to find the prime factorization.

2. 28

3. 50

4. 76

5. 108

6. 55

7. 120

8. 92

Write the prime factorization in exponent form.

9. 27

10. 100

11. 780

Solve for n to complete the prime factorization.

12. $n \times 17 = 51$ _____

13. $3^n \times 2 = 18$ _____

14. $2 \times 2 \times 2 \times n = 40$ _____

Mixed Review

Find the mean, median, and mode.

15. 28, 35, 40, 28, 33, 36, 39, 31

16. 7, 7, 8, 9, 6, 6, 7, 10, 10, 9

17. 428, 472, 510, 386, 440

18. 78, 80, 95, 83, 100, 89, 88, 95

19. There are 24 students in Mrs. Garcia's class. She wants to divide the class evenly into groups of at least 4 students. Write the ways in which she can divide the class.

Name _____

Least Common Multiple and Greatest Common Factor**Vocabulary**

Complete.

1. The smallest of the common multiples is called the

_____.

2. The largest of the common factors is called the

_____.

List the first five multiples of each number.

3. 9

4. 14

5. 22

Find the LCM of each set of numbers.

6. 12, 18

7. 7, 14

8. 16, 20

9. 4, 5, 6

10. 2, 6, 7

Find the GCF of each set of numbers.

11. 15, 45

12. 6, 14

13. 24, 40

14. 8, 12, 52

15. 16, 24, 32

Find a pair of numbers for each set of conditions.

16. The LCM is 35.
The GCF is 7.

17. The LCM is 36
The GCF is 1.

18. The LCM is 120.
The GCF is 10.

Mixed Review

Determine whether each number is divisible by 2, 3, 4, 5, 6, 8, 9, or 10.

19. 72 _____

20. 80 _____

21. 324 _____

22. 1500 _____

Solve for n to complete the prime factorization.

23. $2 \times n \times 7 = 42$ _____

24. $3^2 \times n = 63$ _____

25. $5 \times 7 \times n = 385$ _____

Find the quotient.

26. $24.14 \div 7.1$ _____

27. $17.29 \div 3.8$ _____

28. $65.024 \div 6.35$ _____

Name _____

Problem Solving Strategy: Make an Organized List

Solve the problem by making an organized list.

- | | |
|--|---|
| <p>1. Jack and Ashley begin jogging around a quarter-mile track at the same time. Ashley takes 2 minutes to complete each lap and Jack takes 3 minutes. How many laps will each have run the first time they are side-by-side again at the point where they began?</p> <p>_____</p> | <p>2. Terrence is taking two medications for his flu. He begins taking them both at 10:00 P.M. on Tuesday. If he takes one every 8 hours and the other every 10 hours, on what day and at what time will he take the two medications together again?</p> <p>_____</p> |
| <p>3. A large high school has a marching band with 64 woodwind players and 72 brass players. All members of the band line up in rows of equal size. Only musicians playing the same instruments are in the same row. What is the greatest number of musicians who can be in one row?</p> <p>_____</p> | <p>4. Brice plays in a basketball league. In his last game, he scored more than 20 but fewer than 30 points making a combination of 2- and 3-point shots. If he made 5 more 2-point shots than 3-point shots, how many of each type did he make?</p> <p>_____</p> |
| <p>5. Aki is buying franks and buns for a field trip. She sees franks in packages of 6 and buns in packages of 8. There are 70 people going on the trip. What is the least number of each she can buy so there are franks and buns for everyone, with no extra packages?</p> <p>_____</p> <p>_____</p> | <p>6. Kiona has 235 CDs. She is buying CD holders for her collection. The two types that she likes hold 20 CDs and 12 CDs each. She wants to buy the same number of each type. What is the least number of each type of CD holder that Kiona will have to buy to hold her entire CD collection?</p> <p>_____</p> <p>_____</p> |

Mixed Review

Estimate the sum or difference.

7. $80 + 31 + 87$

8. $710 - 189$

9. $1,208 + 877 + 439$

10. $7,151 - 2,993$

11. $67 + 123 + 804$

12. $920 - 592$

Equivalent Fractions and Simplest Form

Vocabulary

Complete.

- When the numerator and denominator of a fraction have no common factor other than 1, the fraction is in _____.
- Fractions that name the same amount or the same part of a whole are called _____.

Write the factors common to the numerator and denominator.

- | | | | | |
|--------------------|--------------------|---------------------|--------------------|--------------------|
| 3. $\frac{8}{32}$ | 4. $\frac{10}{50}$ | 5. $\frac{2}{13}$ | 6. $\frac{14}{49}$ | 7. $\frac{1}{19}$ |
| _____ | _____ | _____ | _____ | _____ |
| 8. $\frac{12}{18}$ | 9. $\frac{25}{75}$ | 10. $\frac{15}{40}$ | 11. $\frac{9}{54}$ | 12. $\frac{6}{33}$ |
| _____ | _____ | _____ | _____ | _____ |

Write the fraction in simplest form.

- | | | | | |
|---------------------|---------------------|----------------------|---------------------|---------------------|
| 13. $\frac{9}{36}$ | 14. $\frac{15}{50}$ | 15. $\frac{11}{121}$ | 16. $\frac{15}{36}$ | 17. $\frac{14}{28}$ |
| _____ | _____ | _____ | _____ | _____ |
| 18. $\frac{30}{66}$ | 19. $\frac{63}{72}$ | 20. $\frac{27}{81}$ | 21. $\frac{25}{65}$ | 22. $\frac{12}{42}$ |
| _____ | _____ | _____ | _____ | _____ |

Complete.

- | | | | | |
|---|--|--|---|---|
| 23. $\frac{36}{72} = \frac{1}{\square}$ | 24. $\frac{\square}{75} = \frac{2}{3}$ | 25. $\frac{17}{\square} = \frac{1}{5}$ | 26. $\frac{63}{84} = \frac{3}{\square}$ | 27. $\frac{2}{\square} = \frac{64}{96}$ |
|---|--|--|---|---|

Mixed Review

Tell whether you would use a bar, line, or circle graph to display the data.

- The number of students in each grade at your school _____
- A hospital patient's temperature taken each hour for 8 hours _____
- The part of each day you spend at various activities _____

Mixed Numbers and Fractions

Vocabulary

Complete.

1. A _____ has a whole-number part and a fraction part.
-

Write the fraction as a mixed number or a whole number.

2. $\frac{20}{5}$

3. $\frac{19}{4}$

4. $\frac{22}{7}$

5. $\frac{39}{10}$

6. $\frac{19}{10}$

7. $\frac{75}{15}$

8. $\frac{44}{13}$

9. $\frac{50}{7}$

10. $\frac{63}{21}$

11. $\frac{41}{8}$

12. $\frac{25}{6}$

13. $\frac{72}{12}$

14. $\frac{55}{9}$

15. $\frac{46}{5}$

16. $\frac{77}{11}$

Write the mixed number as a fraction.

17. $6\frac{2}{7}$

18. $4\frac{6}{11}$

19. $9\frac{2}{3}$

20. $11\frac{1}{5}$

21. $2\frac{2}{3}$

22. $7\frac{2}{9}$

23. $12\frac{4}{5}$

24. $4\frac{5}{8}$

25. $8\frac{2}{3}$

26. $13\frac{1}{2}$

Mixed Review

Write the prime factorization of each number using exponents.

27. 84

28. 72

29. 300

Write the fraction in simplest form.

30. $\frac{35}{45}$

31. $\frac{36}{42}$

32. $\frac{56}{72}$

33. $\frac{22}{55}$

34. $\frac{18}{81}$

35. $\frac{24}{30}$

36. $\frac{16}{40}$

37. $\frac{24}{36}$

38. $\frac{27}{63}$

39. $\frac{72}{88}$

Name _____

Compare and Order Fractions

Compare the fractions. Write $<$, $>$, or $=$ for each •.

- | | | | |
|---|--|--|---|
| 1. $\frac{5}{6} \bullet \frac{3}{4}$ _____ | 2. $\frac{1}{4} \bullet \frac{1}{5}$ _____ | 3. $\frac{2}{3} \bullet \frac{3}{8}$ _____ | 4. $\frac{5}{8} \bullet \frac{3}{4}$ _____ |
| 5. $\frac{9}{10} \bullet \frac{7}{8}$ _____ | 6. $\frac{7}{12} \bullet \frac{3}{4}$ _____ | 7. $\frac{13}{16} \bullet \frac{5}{6}$ _____ | 8. $\frac{1}{7} \bullet \frac{1}{6}$ _____ |
| 9. $\frac{2}{5} \bullet \frac{5}{6}$ _____ | 10. $\frac{9}{15} \bullet \frac{3}{5}$ _____ | 11. $\frac{4}{7} \bullet \frac{3}{5}$ _____ | 12. $\frac{7}{8} \bullet \frac{17}{20}$ _____ |
| 13. $\frac{4}{5} \bullet \frac{16}{20}$ _____ | 14. $\frac{7}{9} \bullet \frac{2}{3}$ _____ | 15. $\frac{1}{9} \bullet \frac{2}{3}$ _____ | 16. $\frac{5}{9} \bullet \frac{6}{11}$ _____ |

Use the number line to order the fractions from least to greatest.

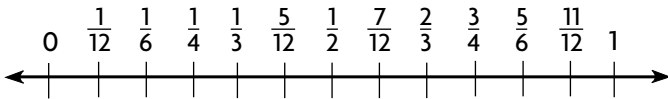

- | | | |
|--|---|--|
| 17. $\frac{1}{6}, \frac{5}{12}, \frac{1}{3}$
_____ | 18. $\frac{5}{6}, \frac{7}{12}, \frac{1}{2}$
_____ | 19. $\frac{3}{4}, \frac{11}{12}, \frac{2}{3}$
_____ |
| 20. $\frac{2}{3}, \frac{7}{12}, \frac{5}{12}$
_____ | 21. $\frac{1}{2}, \frac{5}{6}, \frac{1}{6}$
_____ | 22. $\frac{7}{12}, \frac{1}{6}, \frac{1}{3}$
_____ |

Order the fractions from least to greatest.

- | | | |
|---|---|---|
| 23. $\frac{1}{4}, \frac{1}{6}, \frac{2}{5}$
_____ | 24. $\frac{4}{5}, \frac{2}{3}, \frac{3}{10}$
_____ | 25. $\frac{1}{5}, \frac{3}{8}, \frac{4}{5}$
_____ |
| 26. $\frac{7}{8}, \frac{4}{5}, \frac{9}{10}$
_____ | 27. $\frac{3}{4}, \frac{7}{10}, \frac{5}{7}$
_____ | 28. $\frac{3}{5}, \frac{1}{8}, \frac{3}{10}$
_____ |

Mixed Review

Find the mean, median, and mode

- | | | |
|-------------------------------------|-------------------------------------|---------------------------------------|
| 29. 6, 6, 2, 4, 8, 6, 5, 3
_____ | 30. 23, 26, 24, 19, 31, 33
_____ | 31. 12, 9, 21, 11, 15, 15, 8
_____ |
|-------------------------------------|-------------------------------------|---------------------------------------|

Fractions, Decimals, and Percents

Write the decimal as a fraction.

1. 0.5 _____

2. 0.14 _____

3. 0.06 _____

4. 0.83 _____

5. 0.62 _____

6. 0.317 _____

7. 0.805 _____

8. 0.955 _____

Write as a decimal. Tell whether the decimal terminates or repeats.

9. $\frac{3}{10}$ _____

10. $\frac{6}{9}$ _____

11. $\frac{7}{12}$ _____

12. $\frac{11}{20}$ _____

13. $\frac{7}{30}$ _____

14. $\frac{9}{10}$ _____

15. $\frac{7}{15}$ _____

16. $\frac{4}{11}$ _____

Compare. Write $<$, $>$, or $=$ for each •.

17. $0.24 \cdot \frac{1}{4}$ _____

18. $0.18 \cdot \frac{7}{50}$ _____

19. $\frac{4}{10} \cdot 0.44$ _____

20. $\frac{1}{5} \cdot 0.19$ _____

21. $\frac{7}{20} \cdot 0.45$ _____

22. $\frac{9}{20} \cdot 0.45$ _____

Write the fraction as a percent.

23. $\frac{3}{5}$ _____

24. $\frac{17}{100}$ _____

25. $\frac{4}{2}$ _____

26. $\frac{1}{500}$ _____

27. $\frac{9}{25}$ _____

28. $\frac{7}{5}$ _____

29. $\frac{6}{40}$ _____

30. $\frac{17}{20}$ _____

Mixed Review

Estimate.

31. $56.09 \div 7.1$

32. $64.1 - 13.9$

33. $97.6 \div 9.8$

34. $\$1.79 - \0.82

35. 188.2×21.3

36. $602.5 + 102.4$

37. $\$49.34 \times 5$

38. $711.2 + 798.5$

Evaluate the expression.

39. $6 + 4 \times 3$ _____

40. $18 - 6 + 2$ _____

41. $(10 \times 3) \div 6$ _____

Name _____

Estimate Sums and Differences

Use the number line to tell whether the fraction is close to 0, $\frac{1}{2}$, or 1. Write *close to 0*, *close to $\frac{1}{2}$* , or *close to 1*.

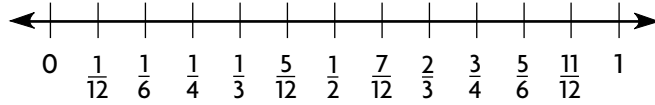

1. $\frac{2}{3}$

2. $\frac{1}{12}$

3. $\frac{11}{12}$

4. $\frac{1}{3}$

Estimate the sum or difference.

5. $\frac{4}{5} + \frac{1}{8}$

6. $\frac{5}{6} - \frac{2}{3}$

7. $\frac{1}{10} + \frac{4}{7}$

8. $\frac{3}{4} + \frac{9}{10}$

9. $5\frac{3}{5} + 1\frac{7}{8}$

10. $6\frac{10}{11} - 3\frac{1}{15}$

11. $4\frac{2}{9} + 3\frac{6}{7}$

12. $8\frac{7}{9} - 3\frac{11}{12}$

13. $\frac{1}{7} + \frac{9}{11}$

14. $\frac{4}{7} - \frac{1}{2}$

15. $\frac{5}{11} + \frac{8}{10}$

16. $\frac{3}{4} - \frac{1}{9}$

17. $9\frac{11}{14} - 1\frac{7}{10}$

18. $5\frac{2}{3} + 4\frac{1}{6}$

19. $8\frac{5}{7} - 3\frac{4}{5}$

20. $6\frac{7}{16} - 4\frac{5}{6}$

Use a range to estimate each sum or difference.

21. $7\frac{3}{4} - 1\frac{1}{12}$

22. $12\frac{11}{21} - 4\frac{3}{8}$

23. $13\frac{8}{9} + 1\frac{4}{5}$

24. $6\frac{2}{15} + 4\frac{3}{7}$

Mixed Review

Write the fraction in simplest form.

25. $\frac{15}{20}$ _____

26. $\frac{16}{28}$ _____

27. $\frac{48}{96}$ _____

28. $\frac{28}{36}$ _____

29. $\frac{5}{45}$ _____

30. $\frac{8}{32}$ _____

31. $\frac{36}{63}$ _____

32. $\frac{25}{125}$ _____

Evaluate the expression for $m = 8$ and $n = 3$.

33. $4 + m \div 2$ _____

34. $6 \times n + 7$ _____

35. $15 - n \times 2$ _____

Add and Subtract Fractions

Use the LCD to rewrite each problem with equivalent fractions.

1. $\frac{3}{8} + \frac{1}{2}$

2. $\frac{3}{4} - \frac{1}{6}$

3. $\frac{2}{3} + \frac{4}{5}$

4. $\frac{8}{9} - \frac{1}{3}$

5. $\frac{1}{4} + \frac{3}{7}$

Write the sum or difference in simplest form. Estimate to check.

6. $\frac{1}{2} + \frac{1}{5}$

7. $\frac{6}{7} - \frac{1}{4}$

8. $\frac{9}{10} - \frac{3}{5}$

9. $\frac{7}{8} - \frac{1}{2}$

10. $\frac{3}{4} + \frac{5}{8}$

11. $\frac{4}{5} - \frac{1}{3}$

12. $\frac{5}{8} + \frac{1}{10}$

13. $\frac{1}{2} - \frac{1}{6}$

14. $\frac{7}{10} + \frac{1}{4}$

15. $\frac{5}{6} + \frac{1}{3}$

16. $\frac{11}{12} - \frac{1}{4}$

17. $\frac{3}{10} + \frac{1}{2}$

18. $\frac{3}{4} + \frac{1}{12}$

19. $\frac{6}{7} - \frac{1}{3}$

20. $\frac{4}{5} - \frac{1}{6}$

21. $\frac{3}{4} + \frac{1}{2}$

22. $\frac{2}{3} - \frac{3}{8}$

23. $\frac{3}{5} + \frac{1}{15}$

24. $\frac{13}{14} - \frac{2}{7}$

25. $\frac{1}{3} - \frac{1}{5}$

26. $\frac{7}{10} - \frac{2}{5}$

27. $\frac{1}{7} + \frac{1}{2}$

28. $\frac{7}{12} - \frac{1}{4}$

29. $\frac{7}{15} - \frac{2}{5}$

30. $\frac{2}{5} + \frac{1}{3}$

31. $\frac{4}{9} + \frac{1}{2}$

32. $\frac{2}{3} - \frac{2}{7}$

33. $\frac{5}{8} + \frac{1}{3}$

34. $\frac{2}{3} + \frac{1}{9}$

35. $\frac{5}{6} - \frac{1}{2}$

Mixed Review

Find the mean, median, and mode.

36. 57, 71, 50, 57, 53, 60

37. 21, 25, 29, 18, 31, 27, 24

Find the quotient.

38. $26.98 \div 3.8$ _____

39. $1.365 \div 0.07$ _____

40. $174.08 \div 27.2$ _____

Name _____

Add and Subtract Mixed Numbers

Draw a diagram to find each sum or difference. Write the answer in simplest form.

1. $1\frac{2}{5} + 1\frac{2}{5}$ _____

2. $2\frac{3}{8} - 1\frac{1}{4}$ _____

3. $2\frac{1}{6} + 1\frac{1}{3}$ _____

4. $3\frac{1}{2} - 1\frac{1}{4}$ _____

5. $2\frac{3}{8} + 1\frac{1}{2}$ _____

6. $2\frac{2}{3} - 1\frac{1}{6}$ _____

Write the sum or difference in simplest form. Estimate to check.

7. $1\frac{1}{5} + 1\frac{1}{4}$ _____

8. $2\frac{1}{2} - 1\frac{1}{8}$ _____

9. $8\frac{5}{12} - 1\frac{1}{4}$ _____

10. $1\frac{1}{6} + 2\frac{2}{3}$ _____

11. $4\frac{3}{4} - 2\frac{3}{8}$ _____

12. $2\frac{1}{2} + 4\frac{4}{5}$ _____

13. $5\frac{7}{9} - 3\frac{2}{3}$ _____

14. $4\frac{3}{5} - 3\frac{1}{10}$ _____

15. $1\frac{1}{6} + 4\frac{3}{4}$ _____

16. $7\frac{1}{3} - 2\frac{1}{4}$ _____

17. $5\frac{5}{6} - 1\frac{2}{3}$ _____

18. $3\frac{2}{5} + 4\frac{1}{6}$ _____

19. $3\frac{1}{2} + 1\frac{5}{8}$ _____

20. $3\frac{7}{8} + 4\frac{1}{3}$ _____

21. $6\frac{5}{8} - 2\frac{2}{5}$ _____

Mixed Review

Write the fraction as a percent.

22. $\frac{1}{4}$ _____

23. $\frac{3}{10}$ _____

24. $\frac{2}{5}$ _____

25. $\frac{5}{100}$ _____

26. $\frac{10}{5}$ _____

27. $\frac{9}{50}$ _____

Write the numbers in order from least to greatest.

28. 0.303, 0.03, 0.33, 0.033

29. 11.10, 10.01, 11.01, 10.10

30. 2.292, 2.922, 2.929, 2.229

31. 0.545, 0.55, 0.445, 0.45

32. 6.626, 6.266, 6.226, 6.662

33. 7.070, 70.07, 7.007, 7.707

Name _____

Subtract Mixed Numbers

Write the difference in simplest form. Estimate to check.

1. $8\frac{3}{4} - 6\frac{1}{2}$

2. $4\frac{1}{5} - 2\frac{7}{10}$

3. $7\frac{1}{4} - 2\frac{2}{3}$

4. $5\frac{2}{9} - 3\frac{2}{3}$

5. $3\frac{1}{5} - 2\frac{3}{10}$

6. $5\frac{3}{8} - 4\frac{1}{2}$

7. $6\frac{1}{3} - 2\frac{3}{4}$

8. $1\frac{7}{9} - 1\frac{2}{3}$

9. $4\frac{2}{3} - 1\frac{1}{2}$

10. $5\frac{4}{5} - 3\frac{1}{4}$

11. $3\frac{1}{3} - 1\frac{4}{9}$

12. $4\frac{5}{8} - 2\frac{1}{2}$

13. $5\frac{1}{6} - 3\frac{2}{3}$

14. $4\frac{3}{5} - 2\frac{7}{10}$

15. $4\frac{1}{8} - 2\frac{3}{4}$

16. $3\frac{1}{2} - 1\frac{4}{5}$

17. $5\frac{1}{4} - 2\frac{3}{8}$

18. $6\frac{1}{4} - 4\frac{2}{5}$

19. $9\frac{3}{8} - 4\frac{1}{3}$

20. $5\frac{1}{6} - 1\frac{5}{8}$

Evaluate each expression for $a = 3\frac{1}{3}$, $b = 2\frac{1}{4}$, $c = 5\frac{1}{6}$.

21. $c - a$

22. $c - b$

23. $a - b$

Mixed Review

Write in exponential form.

24. $5 \times 5 \times 5 \times 5$ _____

25. $10 \times 10 \times 10$ _____

26. $k \times k \times k \times k \times k$ _____

27. $w \times w$ _____

Evaluate each expression.

28. $17.61 - s$ for $s = 12.18$

29. $75.6 \div v$ for $v = 6.3$

30. $5f$ for $f = 8.7$

Name _____

Problem Solving Strategy: Draw a Diagram

Solve the problem by drawing a diagram.

1. In the school art room the students use square tables. Each side of a table is $4\frac{1}{2}$ ft. If some of the tables are placed end-to-end, they form a rectangle with a perimeter of 36 ft. How many tables are used to make the rectangle?

2. The art room is on one side of the hallway with an office, a classroom, and the music room. The art room is between the classroom and the office. The classroom is between the music room and the art room. Which two rooms are on the ends of the hallway?

3. During art class, 2 students can sit at each side of a square table. The students decide to make a large rectangular table by placing 5 square tables end-to-end. How many students will be able to sit at this large table?

4. Richard is cutting a hole in a wall to hold an air conditioner. The front of the air conditioner is a rectangle 26 in. wide and 16 in. high. The wall is 72 in. wide. If the air conditioner is centered in the wall, how wide will the wall be on either side of it?

5. Cassandra is training for a charity walk between two towns. The towns are 12 mi apart. On her first day of training, she walks $4\frac{1}{2}$ mi. If she increases her distance by $1\frac{1}{2}$ mi every 3 days, how many days will it take until Cassandra has walked at least 10 mi?

6. Marla wants to wrap a present that is in the shape of a cube. She wants to put one piece of ribbon around the top, bottom and two sides. She wants to put a second piece around the top, bottom, and other two sides. The box is $8\frac{1}{2}$ in. on each edge. What is the shortest length of ribbon she needs?

Mixed Review

Write the number in standard form.

7. six hundred and three tenths _____
8. ninety-one hundredths _____
9. ninety and seven hundredths _____
10. eighty and nine tenths _____

Find the GCF for each set of numbers.

- | | | | | |
|------------|------------|------------|------------|------------|
| 11. 10, 15 | 12. 16, 40 | 13. 18, 45 | 14. 20, 28 | 15. 24, 56 |
| _____ | _____ | _____ | _____ | _____ |

Name _____

Estimate Products and Quotients

Estimate each product or quotient.

1. $4\frac{1}{4} \times 3\frac{3}{4}$ _____ 2. $20\frac{5}{6} \div 6\frac{3}{4}$ _____ 3. $\frac{3}{4} \times \frac{5}{6}$ _____

4. $\frac{3}{4} \div \frac{2}{3}$ _____ 5. $45\frac{1}{3} \div 8\frac{2}{3}$ _____ 6. $17\frac{2}{7} \times 1\frac{2}{7}$ _____

7. $2\frac{3}{5} \div \frac{2}{5}$ _____ 8. $19 \times 6\frac{1}{3}$ _____ 9. $2\frac{3}{4} \times 2\frac{4}{5}$ _____

10. $36\frac{3}{7} \div 11\frac{3}{4}$ _____ 11. $\frac{7}{9} \times 13\frac{1}{9}$ _____ 12. $\frac{1}{5} \div 20$ _____

13. $3\frac{3}{4} \div 4\frac{1}{2}$ _____ 14. $42\frac{1}{6} \times 14\frac{4}{9}$ _____ 15. $\frac{1}{10} \times \frac{1}{10}$ _____

16. $8\frac{1}{3} \times 6\frac{4}{5}$ _____ 17. $12\frac{1}{6} \div 3\frac{2}{3}$ _____ 18. $40\frac{2}{9} \div 7\frac{4}{5}$ _____

19. $10\frac{5}{6} \times 3\frac{7}{8}$ _____ 20. $18\frac{3}{10} \div 1\frac{6}{7}$ _____ 21. $9\frac{3}{4} \times 17\frac{1}{5}$ _____

Estimate to compare. Write $<$, $>$, or $=$ for \bullet .

22. $3\frac{1}{8} \times 5 \bullet 12 \div \frac{9}{10}$ _____ 23. $6\frac{1}{2} \div 12 \bullet \frac{5}{8} \div 1\frac{2}{3}$ _____

24. $5\frac{2}{7} \div 1\frac{3}{8} \bullet 2\frac{1}{8} \div 3\frac{7}{8}$ _____ 25. $3\frac{3}{4} \times 1\frac{1}{4} \bullet 31\frac{3}{4} \div 8\frac{1}{4}$ _____

26. $15\frac{1}{5} \div 4\frac{2}{3} \bullet 1\frac{3}{4} \div 3\frac{4}{5}$ _____ 27. $7\frac{2}{9} \times 1\frac{5}{7} \bullet 36\frac{1}{2} \div 2\frac{7}{8}$ _____

Mixed Review

Write the fraction as a percent.

28. $\frac{3}{4}$ _____ 29. $\frac{7}{10}$ _____ 30. $\frac{1}{20}$ _____ 31. $\frac{3}{25}$ _____

32. $\frac{29}{50}$ _____ 33. $\frac{13}{10}$ _____ 34. $\frac{1}{8}$ _____ 35. $\frac{5}{8}$ _____

Name _____

Multiply Fractions

Make a model to find the product.

1. $\frac{1}{2} \times 6$

2. $\frac{2}{5} \times \frac{1}{2}$

3. $\frac{1}{8} \times \frac{1}{2}$

4. $10 \times \frac{1}{2}$

5. $\frac{1}{2} \times \frac{1}{3}$

Multiply. Write the answer in simplest form.

6. $\frac{1}{4} \times \frac{1}{6}$

7. $\frac{1}{5} \times \frac{1}{2}$

8. $\frac{3}{8} \times \frac{1}{4}$

9. $\frac{3}{5} \times \frac{1}{4}$

10. $\frac{4}{5} \times \frac{1}{2}$

11. $\frac{1}{4} \times \frac{8}{9}$

12. $\frac{3}{4} \times \frac{2}{7}$

13. $\frac{5}{9} \times \frac{9}{10}$

14. $\frac{5}{6} \times \frac{2}{5}$

15. $\frac{6}{7} \times \frac{2}{3}$

16. $\frac{3}{4} \times \frac{8}{9}$

17. $\frac{3}{4} \times \frac{8}{15}$

18. $\frac{1}{6} \times \frac{8}{9}$

19. $\frac{7}{8} \times 24$

20. $\frac{3}{8} \times \frac{1}{3}$

21. $\frac{5}{6} \times \frac{3}{10}$

22. $\frac{9}{10} \times \frac{2}{3}$

23. $30 \times \frac{4}{5}$

24. $\frac{1}{2} \times \frac{12}{13}$

25. $\frac{9}{11} \times \frac{22}{27}$

Compare. Write $<$, $>$, or $=$ for \bullet .

26. $\frac{1}{2} \times \frac{2}{3} \bullet \frac{2}{3}$

27. $\frac{3}{4} \times 8 \bullet 6$

28. $\frac{1}{4} \times 4 \bullet \frac{1}{4}$

Mixed Review

Write each mixed number as a fraction.

29. $4\frac{2}{5}$

30. $6\frac{3}{7}$

31. $2\frac{8}{11}$

32. $5\frac{3}{5}$

Write each fraction as a mixed number.

33. $\frac{12}{7}$

34. $\frac{41}{12}$

35. $\frac{25}{6}$

36. $\frac{50}{9}$

Name _____

Multiply Mixed Numbers

Use the Distributive Property to multiply.

1. $7 \times 4\frac{1}{6}$

2. $1\frac{1}{4} \times 8$

3. $5\frac{3}{8} \times 3$

4. $6 \times 2\frac{4}{5}$

Multiply. Write your answer in simplest form.

5. $2\frac{1}{2} \times 1\frac{1}{3}$

6. $3\frac{1}{5} \times 2\frac{1}{2}$

7. $8\frac{3}{4} \times \frac{2}{5}$

8. $3\frac{1}{3} \times 1\frac{1}{5}$

9. $3\frac{1}{3} \times 2\frac{2}{5}$

10. $1\frac{3}{4} \times \frac{3}{14}$

11. $4\frac{2}{5} \times \frac{10}{11}$

12. $\frac{6}{7} \times 2\frac{1}{10}$

13. $3\frac{1}{2} \times 1\frac{1}{4}$

14. $2\frac{3}{5} \times 1\frac{2}{3}$

15. $4\frac{3}{8} \times \frac{1}{2}$

16. $6\frac{4}{5} \times \frac{5}{8}$

17. $2\frac{1}{4} \times 3\frac{1}{5}$

18. $9\frac{1}{3} \times 1\frac{2}{7}$

19. $\frac{3}{5} \times 1\frac{2}{3}$

20. $12\frac{1}{3} \times 1\frac{1}{2}$

21. $1\frac{1}{8} \times \frac{1}{3}$

22. $3\frac{3}{4} \times 1\frac{5}{6}$

23. $2\frac{2}{5} \times 1\frac{5}{8}$

24. $5\frac{3}{5} \times 1\frac{2}{7}$

Compare. Write $<$, $>$, or $=$ for \bullet .

25. $2\frac{1}{2} \times 2\frac{3}{4} \bullet 3\frac{1}{2} \times 4$ _____

26. $6\frac{2}{3} \times 3\frac{3}{5} \bullet 3\frac{3}{4} \times 6\frac{2}{5}$ _____

Mixed Review

Use the data in the chart for 27–28.

Quiz Scores								
30	27	21	27	25	30	29	19	15
26	27	28	22	25	23	26	18	17

27. Make a stem-and-leaf plot of the data.

28. Use the stem-and-leaf plot to find the median and mode.

Name _____

Divide Fractions and Mixed Numbers

Write the reciprocal of the number.

1. $\frac{6}{7}$

2. $\frac{1}{9}$

3. 5

4. $\frac{8}{5}$

5. $3\frac{1}{3}$

Find the quotient. Write it in simplest form.

6. $\frac{4}{5} \div \frac{8}{15}$

7. $\frac{7}{10} \div \frac{1}{2}$

8. $\frac{5}{6} \div \frac{1}{2}$

9. $24 \div \frac{1}{2}$

10. $9 \div \frac{1}{6}$

11. $\frac{7}{9} \div \frac{2}{3}$

12. $\frac{9}{10} \div \frac{2}{5}$

13. $\frac{9}{20} \div \frac{3}{4}$

14. $\frac{5}{8} \div \frac{5}{16}$

15. $\frac{5}{6} \div \frac{2}{3}$

16. $\frac{12}{21} \div \frac{4}{7}$

17. $\frac{5}{8} \div \frac{1}{4}$

18. $\frac{3}{4} \div \frac{2}{3}$

19. $\frac{5}{9} \div \frac{5}{6}$

20. $\frac{7}{8} \div 12$

21. $15 \div \frac{5}{9}$

22. $\frac{5}{12} \div \frac{3}{4}$

23. $\frac{3}{8} \div 18$

24. $\frac{7}{10} \div 14$

25. $24 \div \frac{4}{5}$

Mixed Review

Use mental math to find each quotient.

26. $10 \div \frac{1}{4}$

27. $12 \div \frac{1}{6}$

28. $3 \div \frac{1}{10}$

29. $15 \div \frac{1}{2}$

Find the mean, median, and mode.

30. 8, 10, 12, 11, 8, 9, 10, 10

31. 228, 209, 195, 187, 251

Compare. Write $<$, $>$, or $=$ for \bullet .

32. $\frac{4}{5} \bullet \frac{8}{9}$

33. $\frac{5}{13} \bullet \frac{4}{13}$

34. $\frac{6}{15} \bullet \frac{2}{5}$

35. $\frac{6}{7} \bullet \frac{14}{15}$

Name _____

Problem Solving Skill: Choose the Operation

Solve. Name the operations used.

1. Marie practiced piano a total of $17\frac{1}{2}$ hr last week. If she practiced the same amount of time each day, how long did she practice daily?

2. Sylvan withdrew $\frac{2}{5}$ of the amount in his savings account, and spent $\frac{7}{10}$ of that money. What fraction of his total savings does he still have?

3. Ike practices guitar $2\frac{1}{2}$ hr per day, but Jenn only practices $\frac{3}{4}$ hr. How much longer does Ike practice?

4. A painter is going to paint a wall that measures $2\frac{2}{3}$ yd by $4\frac{1}{2}$ yd. What is the area of the wall?

5. José gives each of his 15 patio plants $\frac{3}{4}$ qt of water daily in warm weather. How much water does José use on his plants on a warm day?

6. José waters each of his 15 patio plants with $\frac{1}{2}$ qt water daily in cool weather. How much water can José expect to use on his patio plants during a cool week?

7. Marisol rode her scooter $1\frac{1}{2}$ mi to Athena's home, then $\frac{3}{4}$ mi to Ariel's home, then $1\frac{1}{4}$ mi back to her home. How far did Marisol ride?

8. Bill can polish a car in $2\frac{3}{4}$ hr. Lara and Danny can do the same job working together in $1\frac{1}{2}$ hr. How much faster than Bill can Lara and Danny do the job when working together?

Mixed Review

Write each fraction in simplest form.

9. $\frac{5}{10}$

10. $\frac{20}{50}$

11. $\frac{15}{25}$

12. $\frac{22}{32}$

13. $\frac{21}{24}$

Name _____

Algebra: Fraction Expressions and Equations

Evaluate the expression.

1. $2\frac{1}{4} + x, x = 2\frac{1}{8}$ _____

2. $2\frac{1}{4} + x, x = \frac{1}{2}$ _____

3. $2\frac{1}{4} + x, x = \frac{3}{8}$ _____

4. $y - 2\frac{3}{5}, y = 5\frac{4}{5}$ _____

5. $y - 2\frac{3}{5}, y = 4\frac{7}{10}$ _____

6. $y - 2\frac{3}{5}, y = 6$ _____

7. $\frac{3}{5}s, s = 2$ _____

8. $\frac{3}{5}s, s = \frac{1}{3}$ _____

9. $\frac{3}{5}s, s = 1\frac{2}{3}$ _____

10. $6\frac{2}{7}p, p = \frac{1}{2}$ _____

11. $6\frac{2}{7}p, p = \frac{7}{3}$ _____

12. $6\frac{2}{7}p, p = 2\frac{5}{8}$ _____

13. $x \div 1\frac{1}{2}, x = 4\frac{1}{2}$ _____

14. $x \div 3\frac{1}{4}, x = \frac{1}{4}$ _____

15. $x \div 2\frac{1}{3}, x = 2\frac{1}{3}$ _____

Use mental math to solve the equation.

16. $x + 5\frac{3}{4} = 5\frac{7}{8}$

17. $\frac{1}{2}y = \frac{1}{12}$

18. $z - 8\frac{1}{3} = 12\frac{1}{2}$

19. $w \div \frac{9}{20} = \frac{5}{9}$

20. $\frac{4}{5}n = 3$

21. $c + 4\frac{1}{3} = 7\frac{5}{6}$

22. $m - 6\frac{1}{2} = 5\frac{7}{8}$

23. $d \times \frac{3}{4} = 9\frac{3}{4}$

Mixed Review

Add or subtract. Write the answer in simplest form.

24. $\frac{7}{8} - \frac{3}{4}$

25. $\frac{1}{2} - \frac{1}{12}$

26. $\frac{1}{3} + \frac{1}{2}$

27. $\frac{2}{5} + \frac{9}{20}$

28. $\frac{4}{5} - \frac{3}{7}$

29. $\frac{4}{9} + \frac{3}{10}$

30. $\frac{7}{10} - \frac{1}{6}$

31. $\frac{5}{12} + \frac{8}{15}$

32. $4\frac{1}{2} + 2\frac{1}{4} + 1\frac{1}{8}$ _____

33. $4\frac{3}{8} - 2\frac{3}{4}$ _____

Name _____

Understand Integers**Vocabulary**

Complete.

- _____ include all whole numbers and their opposites.
- The _____ of an integer is its distance from 0.

Write an integer to represent each situation.

3. earning 7 dollars

4. digging a hole 2 feet deep

5. taking 10 steps backward

6. climbing up a mountain 20 feet

Find the absolute value.

7. $|-3|$

8. $|+3|$

9. $|-2|$

10. $|-6|$

11. $|+9|$

12. $|-15|$

13. $|-32|$

14. $|+32|$

15. $|-47|$

16. $|+78|$

17. $|-180|$

18. $|+574|$

Write the opposite integer

19. -5

20. $+13$

21. $+21$

22. -19

23. -25

24. $+37$

Mixed Review

Multiply. Write the answer in simplest form.

25. $\frac{1}{5} \times \frac{6}{7}$

26. $\frac{4}{9} \times \frac{3}{5}$

27. $\frac{4}{5} \times 30$

28. $2\frac{7}{10} \times \frac{2}{3}$

29. $3\frac{3}{4} \times 2\frac{2}{5}$

30. $1\frac{1}{2} \times 3\frac{1}{3}$

Name _____

Rational Numbers

Use the number line to find a rational number between the two given numbers.

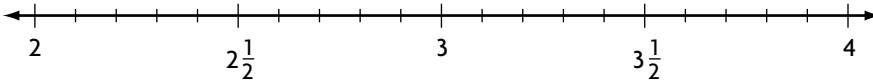

1. 2 and $2\frac{1}{2}$ 2. $2\frac{1}{2}$ and 3 3. 3 and $3\frac{1}{2}$ 4. $3\frac{1}{2}$ and 4
- _____

Find a rational number between the two given numbers.

5. $\frac{3}{8}$ and $\frac{4}{6}$ 6. $\frac{3}{8}$ and $\frac{2}{3}$ 7. $1\frac{7}{8}$ and $1\frac{3}{4}$ 8. -3 and $-3\frac{1}{2}$
- _____
9. 3.1 and 3.2 10. -1.7 and -1.8 11. -5.6 and -5.7 12. 3.04 and 3.05
- _____

Write each rational number in the form $\frac{a}{b}$.

13. $3\frac{1}{2}$ 14. 0.3 15. 0.45 16. 11.2 17. $2\frac{1}{4}$ 18. 3.15
- _____
19. 15 20. 27 21. $3\frac{1}{5}$ 22. 0.59 23. 370 24. $4\frac{1}{7}$
- _____

Use the Venn diagram at the right to determine in which set or sets the number belongs.

25. 1.8 26. $5\frac{2}{3}$ 27. 48
- _____

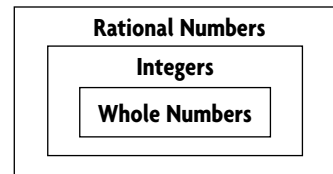

Mixed Review

Write the reciprocal of the number.

28. $\frac{6}{7}$ _____ 29. $1\frac{4}{7}$ _____ 30. 12 _____ 31. $1\frac{1}{7}$ _____

Find the quotient. Write the answer in simplest form.

32. $\frac{2}{5} \div \frac{1}{3}$ _____ 33. $6 \div \frac{8}{9}$ _____ 34. $3\frac{3}{8} \div 1\frac{4}{5}$ _____

Name _____

Compare and Order Rational NumbersCompare. Write $<$ or $>$ for \circ .

1. $0.25 \circ 0.4$

2. $\frac{3}{8} \circ 0.2$

3. $-2\frac{1}{5} \circ -2.3$

4. $-\frac{5}{8} \circ -\frac{3}{10}$

5. $5 \circ -2$

6. $-\frac{7}{10} \circ \frac{4}{5}$

7. $-2.6 \circ -2.62$

8. $\frac{3}{4} \circ \frac{5}{6}$

9. $3.8 + 2.2 \circ 2\frac{1}{6} + 3\frac{4}{5}$

10. $3\frac{1}{2} \times 2 \circ 4\frac{1}{3} + 2.8$

11. $7\frac{1}{4} + 3\frac{1}{3} \circ 1\frac{5}{6} \times 6$

Order the rational numbers from least to greatest.

12. $2.9, -1.7, \frac{9}{3}, \frac{3}{4}$

13. $-\frac{1}{5}, \frac{1}{9}, \frac{1}{10}, -0.1$

14. $0, 0.8, -1.4, -0.6, \frac{3}{5}$

15. $8.7, -9.2, -7.3, 6.2, 6\frac{1}{2}, 8\frac{7}{8}$

16. $4\frac{1}{4}, 4\frac{3}{5}, 4.9, 4.08, 0.49$

Order the rational numbers from greatest to least.

17. $7.3, 6, \frac{7}{8}, 2$

18. $2.4, -1.4, -3, 4.7, 3.8$

19. $\frac{2}{5}, \frac{1}{10}, 0.5, -0.6, 0.42$

Mixed Review

Find the LCM of each set of numbers.

20. 4, 10

21. 7, 12

22. 8, 18, 24

23. 5, 15, 20

Find the GCF of each set of numbers.

24. 12, 20

25. 16, 42

26. 15, 50, 75

27. 36, 54, 72

Find a pair of numbers for each set of conditions.

28. The LCM is 30. The GCF is 2.

29. The LCM is 36. The GCF is 6.

Name _____

Problem Solving Strategy: Use Logical Reasoning

Solve the problems by using logical reasonings.

1. Tamara, Alex, Elena, and Fred entered their dogs in the county dog show. The dogs were a terrier, a setter, a golden retriever, and a Great Dane. Neither girl owned the Great Dane. Neither boy entered a setter. Tamara owns a golden retriever. What breed of dog did Elena enter in the show?

2. Bobby, Ken, Sam, and Ayesha each participate in one sport at school. They play softball, football, basketball, and soccer. Ayesha plays first base. Ken does not play football. If Sam plays soccer, what sport does Bobby participate in?

3. Adel, James, Erica, and An were comparing how far they lived from school. An lives only $\frac{1}{3}$ as far as Adel. James lives twice as far as Erica and 4 times as far as An. If Adel lives 9 blocks from school, how far does Erica live?

4. Ahmed looked over his math homework problems. He saw that $\frac{1}{2}$ of the problems were about fractions, $\frac{1}{3}$ were about decimals, and the rest were about geometry. If there were 4 geometry problems, how many problems did he have in all?

5. Robert, Stanley, and Keith are brothers. Robert is 4 years younger than Stanley. Keith is 3 years older than Robert. Robert is 9 years older than his cousin Richard. If Richard is 11, how old is each brother?

6. Adam, Carin, Dana, and Juanita are lined up for a photograph. As the photographer looks at them, Juanita is to the right of Carin. Adam is on one end. Dana is between Carin and Adam. Give their order from left to right.

Mixed Review

Determine whether each number is divisible by 2, 3, 4, 5, 6, 8, 9, or 10.

7. 125

8. 336

9. 1,010

10. 249

11. 9,072

Multiply. Write the answer in simplest form.

12. $\frac{1}{2} \times \frac{2}{5}$

13. $\frac{3}{5} \times \frac{1}{3}$

14. $\frac{5}{6} \times \frac{1}{4}$

15. $\frac{3}{4} \times \frac{5}{6}$

Name _____

Add Integers

Write the addition problem modeled on the number line.

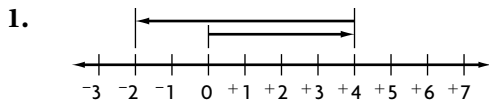

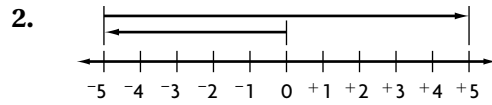

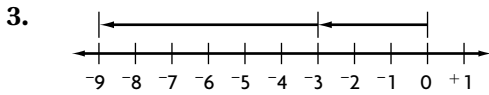

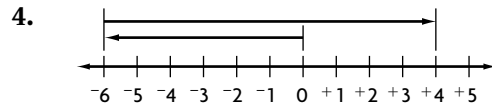

Find the sum.

5. $-8 + -5$

6. $+14 + -9$

7. $-20 + -4$

8. $+31 + -12$

9. $-14 + -16$

10. $+35 + +17$

11. $-23 + -9$

12. $+39 + -15$

13. $-59 + -22$

14. $+47 + -33$

15. $-37 + -26$

16. $+49 + -20$

17. $-19 + -42$

18. $+17 + -12$

19. $+44 + -17$

20. $-64 + -38$

21. $-23 + +50$

22. $-31 + -43$

23. $+85 + -15$

24. $-59 + -21$

Mixed Review

Write the opposite of each number.

25. -12 _____

26. $+81$ _____

27. -54 _____

28. -17 _____

Find the absolute value.

29. $|-45|$ _____

30. $|+101|$ _____

31. $|+310|$ _____

32. $|-287|$ _____

Write each rational number in the form $\frac{a}{b}$.

33. $6\frac{7}{10}$ _____

34. $-9\frac{1}{8}$ _____

35. -1.59 _____

36. 4.03 _____

Name _____

Subtract Integers

Use the number line to find the difference.

1. $-6 - -9 = -6 + +9 =$ _____

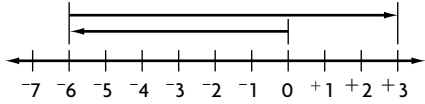

2. $-4 - +5 = -4 + -5 =$ _____

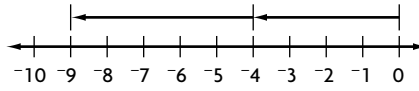

3. $-6 - +5 = -6 + -5 =$ _____

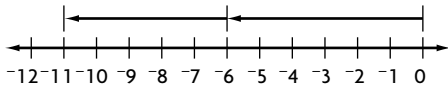

4. $-3 - +7 = -3 + -7 =$ _____

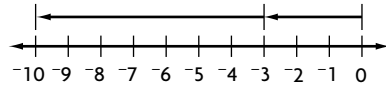

Find the difference.

5. $+8 - -9$

6. $-14 - -6$

7. $+12 - -9$

8. $+6 - -2$

9. $+10 - -3$

10. $+11 - -9$

11. $-14 - -7$

12. $-9 - +3$

13. $-11 - -9$

14. $-9 - +4$

15. $-13 - +5$

16. $-13 - +2$

17. $-19 - +7$

18. $+16 - +12$

19. $+17 - -11$

20. $-18 - -9$

21. $+15 - -14$

22. $-19 - +13$

23. $-21 - +6$

24. $-20 - -8$

Mixed Review

Find a rational number between the two given numbers.

25. 8.3 and 8.26

26. $-4\frac{1}{2}$ and $-4\frac{1}{3}$

27. $-\frac{3}{8}$ and -0.4

28. -1.9 and $-1\frac{3}{4}$

Compare. Write $<$ or $>$ for each \bigcirc .

29. $\frac{2}{3} \bigcirc \frac{4}{5}$

30. $-1.4 \bigcirc -1\frac{3}{8}$

31. $\frac{3}{4} \bigcirc 0.7$

32. $-5.5 \bigcirc -5.6$

Name _____

Algebra: Multiply Integers

Find the product.

1. -7×3

2. -4×-4

3. 9×-2

4. -8×6

5. -4×9

6. 12×-3

7. -3×-8

8. 5×-5

9. 8×-2

10. -6×-9

11. 3×-11

12. -10×-10

13. -20×-4

14. 14×-7

15. -25×4

16. 2×-30

17. 32×-7

18. -45×-2

19. 16×-9

20. -18×-5

21. -3×-15

22. -12×5

23. 3×-10

24. -9×-9

ALGEBRA Use mental math to find the value of y .

25. $y \times 4 = -28$

26. $y \times -2 = -16$

27. $-5 \times y = 30$

28. $9 \times y = 45$

29. $y \times 3 = -45$

30. $y \times -12 = 24$

Mixed Review

Find the sum.

31. $7 + -3$

32. $-10 + 5$

33. $4 + -9$

34. $-13 + -7$

Write the decimal as a fraction.

35. 0.7

36. 0.15

37. 0.03

38. 0.58

Name _____

Divide Integers

Find the quotient.

1. $-10 \div 5$

2. $36 \div -9$

3. $-44 \div -11$

4. $50 \div -2$

5. $-12 \div 4$

6. $35 \div -7$

7. $-44 \div -4$

8. $50 \div -5$

9. $18 \div -3$

10. $-42 \div -7$

11. $45 \div -5$

12. $15 \div 3$

13. $-24 \div -8$

14. $21 \div -3$

15. $-60 \div -6$

16. $-32 \div 8$

17. $55 \div -5$

18. $-36 \div -9$

19. $80 \div -4$

20. $51 \div -3$

21. $-99 \div -11$

22. $56 \div 8$

23. $-100 \div 5$

24. $-200 \div -4$

25. $-75 \div 3$

26. $250 \div -25$

27. $-90 \div -18$

28. $-180 \div 60$

29. $-100 \div -25$

30. $-125 \div 5$

31. $120 \div -4$

32. $-96 \div 16$

33. $105 \div -7$

34. $-84 \div 12$

35. $150 \div -3$

36. $-125 \div 25$

37. $-180 \div -90$

38. $100 \div -4$

39. $-90 \div -5$

40. $-150 \div 50$

ALGEBRA Use mental math to find the value of x .

41. $x \div 5 = -10$

42. $27 \div x = -3$

43. $x \div -15 = -4$

Mixed Review

Multiply. Write the answer in simplest form.

44. $\frac{2}{3} \times \frac{3}{4}$

45. $\frac{1}{8} \times \frac{2}{5}$

46. $\frac{3}{7} \times \frac{1}{4}$

47. $\frac{2}{9} \times \frac{3}{5}$

Find the difference.

48. $12 - -9$

49. $-18 - 6$

50. $4 - 10$

51. $-8 - -15$

Name _____

Combine Operations with Integers

Evaluate the expression.

1. $-3 + 8 \times 2 - 1$

3. $6 \div 2 \times 4 + (4 - -2)$

5. $3^2 - -2 + (7 - 9)$

7. $18 \div 6 + -1 \times 2$

9. $(6^2 - 3^2) \times 2 - -7$

11. $(-10 - -6) + (-1 + 8)$

2. $(5 - 12) \times 6 + 4$

4. $(-8 + 8) + 12 \div -6$

6. $4 + 2^3 - 7 + 1$

8. $7 \times 6 - -4 + 4^2$

10. $3^3 + 2 \times -8 - 5$

12. $(-6 \times -4) \times (-3 + 7)$

Use a property to simplify the expression. Then evaluate the expression and identify the property you used.

13. $-9 + 23 + 29$

14. $(-203 + 18) + -18$

15. $-79 + -187 + -21$

16. $13 + (47 + -3)$

17. $-9 + 16 + 9$

18. $83 + (17 + -18)$

Mixed Review

Find the sum. Write the answer in simplest form.

19. $\frac{1}{4} + \frac{2}{3}$

20. $\frac{3}{8} + \frac{1}{4}$

21. $\frac{5}{6} + \frac{2}{3}$

22. $\frac{1}{2} + \frac{3}{8}$

Use division to find the prime factors. Write the prime factorization.

23. 30

24. 48

25. 36

26. 35

Name _____

Write Expressions

Write an algebraic expression for the word expression.

1. 47 less than the product of y and 7

2. $\frac{3}{4}$ added to 8 times w

3. q times 11 take away the product of 6 and t

4. the difference between a and 4 divided by the sum of b and 9

5. the product of m and 15 divided by the sum of n and 50

6. k times 12 divided by the product of d and 3

Write a word expression for each.

7. $15 - (r + s)$

8. $\frac{g+5}{t}$

9. $k \times m + 1.5$

10. $\frac{20}{bc}$

11. $7.5n + xy$

12. $de - \frac{1}{2}$

Mixed Review

Find the quotient. Write the answer in simplest form.

13. $\frac{2}{3} \div \frac{1}{4}$

14. $\frac{4}{5} \div \frac{2}{15}$

15. $9 \div \frac{3}{8}$

16. $\frac{3}{7} \div \frac{2}{5}$

Find the difference.

17. $7 - ^{-}10$

18. $^{-}6 - 5$

19. $^{-}12 - ^{-}3$

20. $14 - ^{-}18$

Name _____

Evaluate ExpressionsEvaluate the expression for $x = -5, -1, 0,$ and 3 .

1. $4x - 2$

2. $13 - 2x$

3. $-7 + 5x$

4. $\frac{3}{4} - 3x$

5. $6 + 10(x - 3)$

6. $\frac{12}{x-1} - 8$

7. $25 - x^2$

8. $6x \div -3$

9. $-4 \times (x + 5)$

Simplify the expression.

Then evaluate the expression for the given value of the variable.

10. $4x - x + 21$ for $x = 5$

11. $k - 7k - 11$ for $k = -3$

12. $6a + 3b + 27 - 2a$
for $a = -7$ and $b = 6$

13. $m + 30 - 2n + 4m$
for $m = -6$ and $n = 15$

Evaluate the expression for the given value of the variables

14. $4f \times (g - h)$
for $f = -2, g = -10,$ and $h = 12$

15. $r \times (6s + 2t)$
for $r = 4, s = 5,$ and $t = -9$

Mixed ReviewCompare. Write $<$ or $>$.

16. -1.50 _____ -1.55

17. $-\frac{2}{3}$ _____ $\frac{1}{3}$

18. $.80$ _____ $\frac{3}{4}$

19. $-\frac{2}{7}$ _____ $-\frac{5}{6}$

Find the product.

20. -20×6

21. -12×8

22. 7×-11

23. -15×15

24. -7×-40

25. -35×0

26. 9×-12

27. -10×-11

Name _____

Expressions with Squares and Square Roots

Evaluate the expression.

1. $\sqrt{16} + 9$

2. $34 - \sqrt{36}$

3. $11 + \sqrt{49} - 3$

4. $64 - \sqrt{64}$

5. $2^2 + 10 + \sqrt{25}$

6. $\sqrt{16} \times 3$

7. $\sqrt{64} \div 8 \times 1$

8. $9^2 \div 9 + 9$

9. $12^2 \div 6 \times 3$

10. $51 - \sqrt{64} \times 6$

11. $(12 + \sqrt{4}) - 14$

12. $5 \times (7 - 2^2)$

13. $\sqrt{121} + 3 \times 5^2$

14. $-6(\sqrt{81} - \sqrt{64})$

15. $196 \div \sqrt{4} \times 2$

Evaluate the expression for the given value of the variable.

16. $x^2 + \sqrt{64}$ for $x = 6$

17. $\sqrt{121} - \sqrt{m} + 5$ for $m = 100$

18. $(h + 3) - 55$ for $h = \sqrt{49}$

19. $\sqrt{4} \times y^2 + 3$ for $y = 5$

20. $(r^2 + \sqrt{16}) \div 2$ for $r = 8$

21. $7a^2 - \sqrt{a}$ for $a = 4$

Mixed Review

Find the product. Write the answer in simplest form.

22. $\frac{3}{5} \times \frac{2}{3}$

23. $\frac{5}{8} \times \frac{2}{5}$

24. $\frac{1}{2} \times \frac{3}{4}$

25. $\frac{2}{3} \times \frac{1}{6}$

Write each rational number in the form $\frac{a}{b}$.

26. $1\frac{3}{4}$

27. 0.7

28. 0.75

29. 2.25

Connect Words and Equations

Write an equation for the word sentence.

1. 12 less than a number equals 15.

2. The quotient of a number and 7 is 63.

3. 5 more than a number is 31.

4. 6 less than a number r is 16.

5. 3 times the price p equals \$9.45

6. 4 times the number of cars is 84.

7. A number x divided by 2.5 is 3.5.

8. 12 fewer than a number m is $17\frac{1}{2}$

9. 5 times the number of students in the class is 155.

10. The number of auditorium seats divided by 3 is 174.

11. Eight more than your test score is 100.

12. The difference between a number k and -7 is 12.

Mixed Review

Rewrite the problem so that the divisor is a whole number.

13. $9.2 \div 5.4$

14. $7.3 \div 2.6$

15. $19.12 \div 3.4$

16. $67.3 \div 0.18$

Write the fraction in simplest form.

17. $\frac{7}{21}$

18. $\frac{16}{30}$

19. $\frac{9}{24}$

20. $\frac{15}{50}$

21. $\frac{20}{45}$

22. $\frac{12}{18}$

23. $\frac{10}{15}$

24. $\frac{24}{36}$

25. $\frac{33}{55}$

26. $\frac{16}{24}$

Solve Addition Equations

Solve and check. Name the property.

1. $x + 9 = 14$

2. $m + 3.5 = 9$

3. $12 + w = 23$

4. $t + 8.7 = 16.3$

5. $b + 4\frac{1}{3} = 11$

6. $15 = e + 11.2$

7. $n + 6\frac{3}{5} = 9$

8. $18.9 + c = 31.2$

9. $24.6 = 15.7 + h$

10. $14\frac{1}{2} + d = 22$

11. $5\frac{1}{4} = 2\frac{1}{2} + z$

12. $k + 17.8 = 42.1$

13. $9.3 = 5.9 + q$

14. $51 = 29.8 + p$

15. $j + 4 = -7$

16. $8.6 + s = 14.3$

17. $-3 = y + 6$

18. $17\frac{3}{5} = a + 8\frac{1}{2}$

Mixed Review

Estimate.

19. $67.9 - 39.6$

20. $109.4 \div 22$

21. $\$7.78 + \6.19

22. 1.9×15.1

23. $3 \times \$51.99$

24. $202.1 - 58.3$

25. $6.71 + 19.03$

26. $599.2 \div 3.9$

Write the percent or decimal.

27. 16% _____

28. 7% _____

29. 0.65 _____

30. 19% _____

31. 0.54 _____

32. 0.02 _____

33. 10% _____

34. 0.42 _____

35. 90% _____

36. 0.09 _____

Solve Subtraction Equations

Solve and check. .

1. $t - 1 = 9$

2. $12 = x - 3$

3. $b - 6 = 2$

4. $4 = a - 3$

5. $y - 4 = 19$

6. $1 = n - 50$

7. $c - 1.5 = 7$

8. $4.4 = h - 13.4$

9. $k - 7.3 = 12.7$

10. $4\frac{1}{3} = z - \frac{2}{3}$

11. $f - 8\frac{3}{4} = 5$

12. $10\frac{5}{8} = w - 8$

13. $36.5 = g - 18.6$

14. $e - 2\frac{1}{3} = 4\frac{1}{2}$

15. $42 = v - 3\frac{2}{9}$

16. $m - 31 = 2\frac{1}{4}$

17. $6.8 = p - 14.5$

18. $s - 1.9 = 5.4$

Mixed Review

Find the product.

19. $10 \times ^{-}5$

20. $^{-}9 \times ^{-}9$

21. $^{-}3 \times 12$

22. $^{-}11 \times ^{-}4$

Find the sum or difference. Write the answer in simplest form.

23. $4\frac{2}{3} + 7\frac{3}{4}$

24. $8\frac{5}{8} - 1\frac{2}{5}$

25. $2\frac{5}{6} + 3\frac{1}{3}$

26. $3\frac{1}{8} - 1\frac{3}{4}$

27. $1\frac{3}{4} - 1\frac{1}{6}$

28. $3\frac{1}{2} + 4\frac{3}{5}$

29. $5\frac{5}{7} - 1\frac{1}{2}$

30. $5\frac{1}{3} - 2\frac{5}{6}$

Name _____

Solve Multiplication and Division Equations

Solve and check.

1. $3y = 9$

2. $4p = 24$

3. $\frac{x}{2} = 7$

4. $\frac{s}{3} = 5$

5. $20 = 4n$

6. $32 = 8k$

7. $7 = \frac{a}{9}$

8. $4 = \frac{m}{8}$

9. $2x = 8$

10. $3c = 18$

11. $\frac{a}{4} = 8$

12. $\frac{m}{5} = 4$

13. $6 = \frac{k}{4}$

14. $60 = 5y$

15. $11 = \frac{b}{6}$

16. $45 = 3n$

17. $140 = 14g$

18. $513 = \frac{w}{3}$

19. $1,320 = 22d$

20. $19 = \frac{g}{11}$

Solve and check. HINT: Write each mixed number as a fraction.

21. $\frac{12}{17} = \frac{k}{68}$

22. $\frac{x}{7} = 9\frac{1}{3}$

23. $\frac{5}{8}n = 3\frac{3}{4}$

24. $\frac{2}{3}m = 2\frac{1}{6}$

Mixed Review

Solve and check.

25. $a - 11 = 27$

26. $18.4 = b - 3.69$

27. $c - 6\frac{1}{3} = 14\frac{2}{3}$

28. $1\frac{5}{8} + n = 5\frac{1}{4}$

Multiply. Write the answer in simplest form.

29. $2\frac{1}{4} \times 3\frac{2}{3}$

30. $9\frac{1}{5} \times 1\frac{3}{4}$

31. $4\frac{3}{8} \times 2\frac{2}{5}$

32. $2\frac{2}{5} \times 1\frac{2}{3}$

33. $6\frac{3}{5} \times 2\frac{1}{3}$

34. $2\frac{2}{3} \times 3\frac{3}{8}$

35. $1\frac{1}{2} \times 5\frac{5}{6}$

36. $1\frac{1}{4} \times 3\frac{1}{5}$

Name _____

Use FormulasUse the formula $d = rt$ to complete.

- | | | |
|--|---|---|
| 1. $d =$ _____
$r = 20$ mi per hr
$t = 4$ hr | 2. $d =$ _____
$r = 17$ ft per sec
$t = 42$ sec | 3. $d =$ _____
$r = 9.8$ km per hr
$t = 5.3$ hr |
| 4. $d = 75$ mi
$r =$ _____
$t = 3$ hr | 5. $d = 1,320$ km
$r =$ _____
$t = 220$ min | 6. $d = 99$ ft
$r =$ _____
$t = 11$ sec |
| 7. $d = 605$ mi
$r = 55$ mi per hr
$t =$ _____ | 8. $d = 336$ ft
$r = 28$ ft per sec
$t =$ _____ | 9. $d = 500$ ft
$r = 25$ ft per min
$t =$ _____ |

Convert the temperature to degrees Fahrenheit. Write your answer as a decimal.

- | | | | | | |
|-----------------------------------|-----------------------------------|-----------------------------------|------------------------------------|-----------------------------------|-----------------------------------|
| 10. 30°C
_____ | 11. 25°C
_____ | 12. 50°C
_____ | 13. 13°C
_____ | 14. 3°C
_____ | 15. 60°C
_____ |
| 16. 22°C
_____ | 17. 54°C
_____ | 18. 7°C
_____ | 19. 100°C
_____ | 20. 15°C
_____ | 21. 0°C
_____ |

Convert the temperature to degrees Celsius. Write your answer as a decimal and round to the nearest tenth of a degree.

- | | | | | | |
|-----------------------------------|-----------------------------------|------------------------------------|------------------------------------|------------------------------------|------------------------------------|
| 22. 71°F
_____ | 23. 50°F
_____ | 24. 140°F
_____ | 25. 90°F
_____ | 26. 45°F
_____ | 27. 121°F
_____ |
| 28. 32°F
_____ | 29. 49°F
_____ | 30. 96°F
_____ | 31. 130°F
_____ | 32. 113°F
_____ | 33. 86°F
_____ |

Mixed ReviewWrite each rational number in the form $\frac{a}{b}$.

- | | | | |
|-----------------------------|--------------------|------------------------------|-----------------------|
| 34. $2\frac{1}{3}$
_____ | 35. 5.1
_____ | 36. $-8\frac{2}{5}$
_____ | 37. -1.667
_____ |
|-----------------------------|--------------------|------------------------------|-----------------------|

Estimate.

- | | | | |
|--------------------------------|------------------------------|------------------------------|------------------------------|
| 38. 5.4×19.7
_____ | 39. $41.6 \div 6.8$
_____ | 40. $187.51 - 90.4$
_____ | 41. $276.7 + 389.5$
_____ |
|--------------------------------|------------------------------|------------------------------|------------------------------|

Name _____

Problem-Solving Strategy: Work Backward

Solve the problem by working backward.

- | | |
|--|--|
| <p>1. Keesha went to the movies with her brother, Merle, and spent \$15.00. The tickets cost \$4.50 each. She bought a box of popcorn and 2 drinks. The drinks cost \$1.50 each. How much did the popcorn cost?</p> <p>_____</p> | <p>2. Alex brought 48 cookies to school to celebrate his birthday. He gave 9 to teachers. He then shared equally the remaining cookies with his 18 classmates. How many cookies remained?</p> <p>_____</p> |
| <p>3. An engineer is checking wells on a hillside. He starts at his van and walks up 100 m to Well 1. He climbs down 50 m to Well 2. Then he climbs up 200 m to Well 3, which is 280 m above Well 4. How high is each well from the engineer's van?</p> <p>_____</p> | <p>4. Karen had a bag of oats. She used $1\frac{1}{4}$ c in a meatloaf and $3\frac{1}{4}$ c to make cookies. To make granola, Karen used twice the amount of oats she used to make cookies. If there are 4 c of oats left over, how much oats did Karen start with?</p> <p>_____</p> |
| <p>5. Maya paid \$174 for a car she rented for 4 days. The rate was \$36 per day. Maya also had to pay \$0.20 per mi after the first 200 mi driven. How many miles did Maya drive the rented car?</p> <p>_____</p> | <p>6. Miguel poured some punch into the pitcher. Tim added 16 oz more. Bill then added enough punch to double the amount in the pitcher. The pitcher contains 72 oz. How much punch did Miguel pour into the pitcher?</p> <p>_____</p> |

Mixed Review

Write an algebraic expression for the word expression.

- | | | |
|------------------------------|---------------------------------------|--|
| 7. 4.7 more than 5 times x | 8. the quotient of t and 4.2 less 5 | 9. the product of p , $4n$ and m . |
| _____ | _____ | _____ |

Find the product.

- | | | |
|-----------------------------|---------------------------------|--------------------------------|
| 10. $^{-}9 \times 5$ _____ | 11. $15 \times ^{-}3$ _____ | 12. $^{-}8 \times ^{-}6$ _____ |
| 13. $22 \times ^{-}7$ _____ | 14. $^{-}12 \times ^{-}5$ _____ | 15. $^{-}105 \times 3$ _____ |

Points, Lines, and Planes

Name the geometric figure.

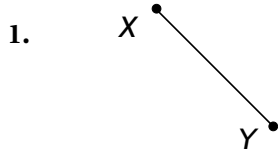

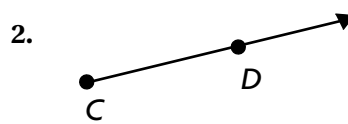



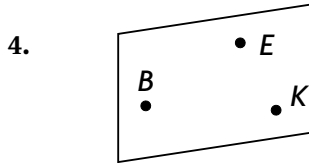

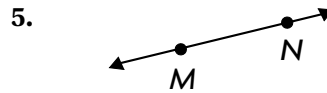

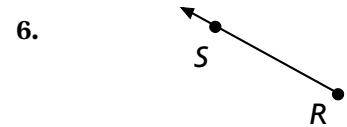

For Exercises 7–9, use the figure at the right.

7. Name three points.

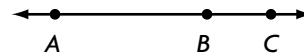

8. Name four different rays.

9. Name six different line segments.

Mixed Review

Solve and check.

10. $\frac{n}{5} = 40$

11. $7x = 63$

12. $-25 = \frac{k}{6}$

13. $4.7 = \frac{d}{2.1}$

14. $84 = 7c$

15. $s \div 1.05 = 800$

16. $-3m = -450$

17. $129.5 = -7g$

Write the sum or difference. Write the answer in simplest form.

18. $\frac{2}{3} + \frac{1}{4}$

19. $\frac{3}{5} - \frac{1}{2}$

20. $\frac{1}{8} + \frac{1}{6}$

21. $\frac{5}{8} - \frac{2}{5}$

22. $\frac{1}{3} - \frac{2}{9}$

23. $\frac{1}{4} + \frac{3}{5}$

24. $\frac{3}{4} - \frac{1}{3}$

25. $\frac{3}{7} + \frac{1}{2}$

Name _____

Angle Relationships

For 1–4 use the figure.

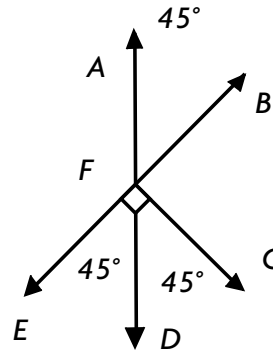

1. Name two angles adjacent to $\angle AFB$.

2. Name an angle vertical to $\angle EFD$.

3. Name an angle that is complementary to $\angle DFC$.

4. Name two angles that are supplementary to $\angle AFE$.

Find the unknown angle measure. The angles are complementary.

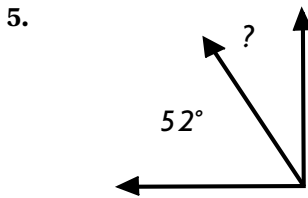

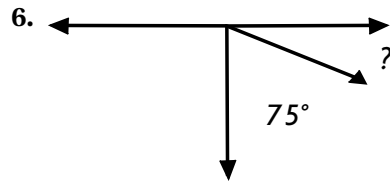

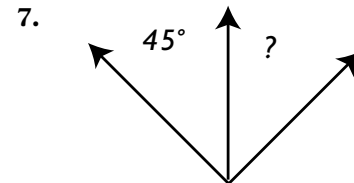

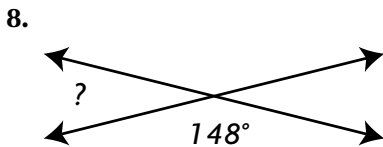

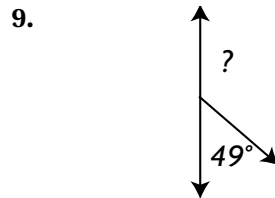

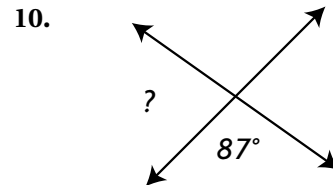

Mixed Review

Solve and check.

11. $y + 9 = 14$

12. $5 + c = -7$

13. $4.3 = x + 1.8$

14. $p + 9\frac{1}{3} = 14\frac{2}{3}$

Write the prime factorization in exponent form.

15. 24

16. 144

17. 360

Classifying Lines

Classify the lines.

1.

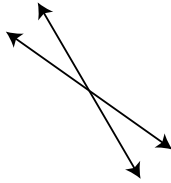

2.

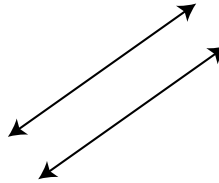

3.

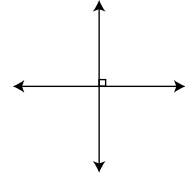

The figure at the right is a rectangular prism.

4. Name all lines that are parallel to \overleftrightarrow{TW} .

5. Name all the lines that intersect \overleftrightarrow{PQ} .

6. Name all the lines that are perpendicular to and intersect \overleftrightarrow{UQ} .

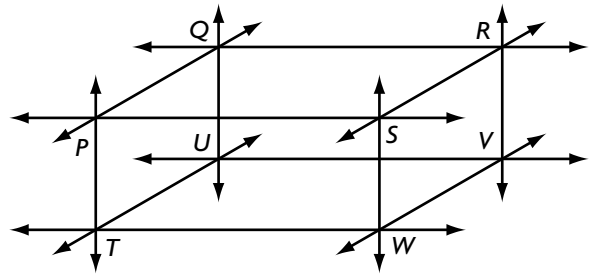

7. Name all the lines that are parallel to RV . _____

8. Is line \overleftrightarrow{PS} perpendicular to line \overleftrightarrow{QU} ? _____

9. Is line \overleftrightarrow{PQ} parallel to line \overleftrightarrow{UV} ? _____

Mixed Review

Find the product.

10. 3×-9 _____ 11. -12×8 _____ 12. -4×-10 _____ 13. -6×15 _____

14. -11×-10 _____ 15. -5×20 _____ 16. -9×8 _____ 17. 7×-50 _____

Add or subtract.

18. $12.29 - 1.07$ _____ 19. $8.791 + 0.45$ _____

20. $0.602 - 0.060$ _____ 21. $527.4 + 43.685$ _____

Name _____

Triangles

Find the measure of the angle and classify the triangle.

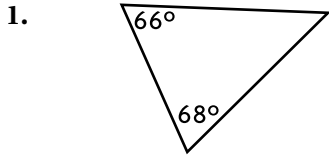

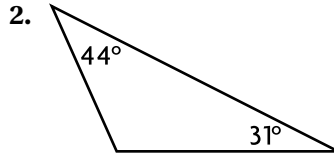

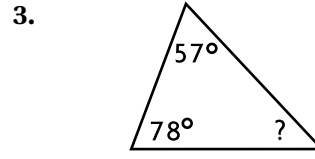

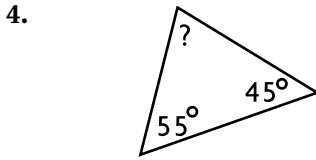

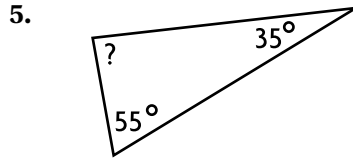

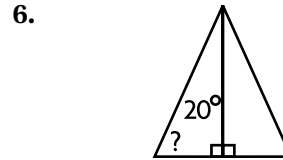

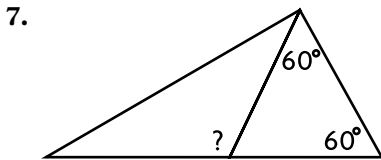

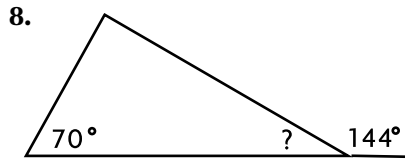

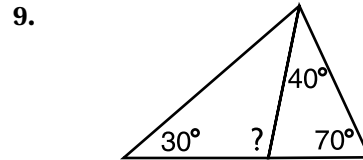

For 10–17, use the figure at the right. Line AB is parallel to line CD . Find the measure of each angle.

- 10. $\angle 1$ _____
- 11. $\angle 2$ _____
- 12. $\angle 3$ _____
- 13. $\angle 4$ _____
- 14. $\angle 5$ _____
- 15. $\angle 6$ _____
- 16. $\angle 7$ _____
- 17. $\angle 8$ _____

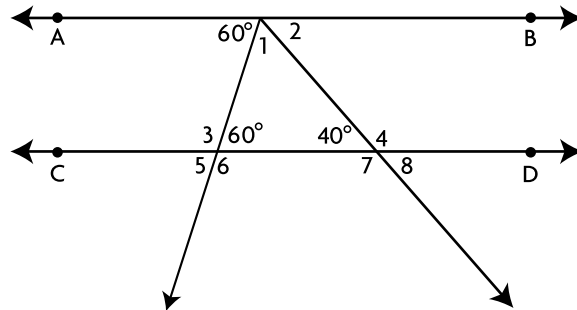

Mixed Review

Evaluate.

- 18. $+4 - -6 - +10$ _____
- 19. $-3 - +2 - -4$ _____
- 20. $-8 - -5 - +7$ _____

Evaluate the expression.

- 21. $-5(\sqrt{64} - 3)$ _____
- 22. $3^2 + \sqrt{81}$ _____
- 23. $\sqrt{100} \div 5 \times 2^2$ _____

Problem Solving Strategy: Find a Pattern

Solve the problem by finding a pattern.

1. The Auto Stop is advertising a special sale: buy 3 cans of motor oil, get 1 can free. How many cans should you buy in order to get 36 cans of motor oil?

2. The Auto Stop charges \$2.09 for a can of motor oil. Adam spends \$37.62 on oil during the “buy 3 cans, get 1 free” sale. How many cans of oil did he get in all?

3. The school cafeteria serves both ice cream and apples for dessert. Twenty-five students choose ice cream for every 6 students who choose apples. In one week, the cafeteria served 600 ice creams. How many students chose apples?

4. Barry and Cecilia are playing a number game. One of them thinks of a number pattern and gives the first six numbers. The other has to name the next number in the pattern. Barry gave Cecilia these numbers: 3, 4, 7, 11, 18, 29. Cecilia correctly gave the next number. What number did she give?

5. Twenty-four students went on the school trip to the science museum. The admission price was \$4.00 per student, but 1 student was admitted free for every 3 students who paid. What was the total cost?

6. The floor of a 17 ft by 13 ft sun room is tiled with tiles that are 1 ft². The tiles alternate between black and white. If there is a black tile in one corner of the room, how many black tiles will be needed in all?

Mixed Review

Use a property to simplify the expression. Then evaluate the expression and identify the property you used.

7. $-3 + 16 + 23$
 8. $(24 + 37) + 63$
 9. $-73 + 120 + -27$
- _____

Write the fraction in simplest form.

10. $\frac{14}{48}$
 11. $\frac{27}{45}$
 12. $\frac{24}{60}$
 13. $\frac{15}{90}$
 14. $\frac{20}{64}$
- _____

Quadrilaterals

Name the geometric figure.

1.

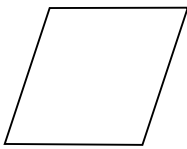

2.

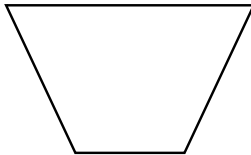

3.

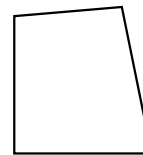

4.

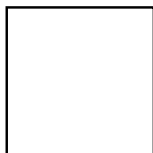

5.

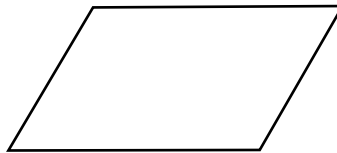

6.

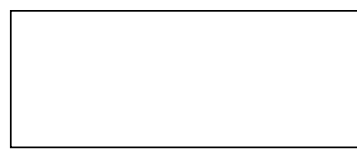

Complete the statement, giving the most exact name for the figure.

7. A quadrilateral with exactly one pair of parallel sides is a

8. A polygon with four sides and no pair of parallel sides is a

Diagonals of a quadrilateral are lines drawn from one vertex to the opposite vertex. Complete the statements about diagonals.

9. If a quadrilateral has four congruent sides, but its diagonals are not congruent, then the quadrilateral is a

10. If a quadrilateral has four congruent sides and its diagonals are congruent, then the quadrilateral is a

Mixed Review

Evaluate each expression.

11. $3.81 \div m$ for $m = 3$

12. $9w$ for $w = 4.7$

13. $8.02 - r$ for $r = 5.6$

Tell whether you would survey the population or use a sample. Explain.

14. You want to know how far each student in your class lives from school.

15. You want to know the percentage of a certain car that is red.

Draw Two-Dimensional Figures

Draw the figure. Use square dot paper or isometric dot paper.

1. an obtuse isosceles triangle
2. a quadrilateral with opposite sides congruent and no right angles
3. a quadrilateral with exactly one pair of parallel sides
4. a pentagon with three congruent sides
5. a quadrilateral with no congruent sides
6. a triangle with all sides congruent
7. a pentagon with all sides congruent
8. a quadrilateral with four right angles and two pairs of congruent sides
9. a quadrilateral with all sides congruent and four right angles
10. a hexagon with all sides congruent
11. a rectangle with all sides congruent
12. a right scalene triangle

Mixed Review

Solve and check.

13. $8.7 = 5.8 + w$

14. $y + 3.6 = 17.1$

15. $23.5 + c = 35.3$

Compare the fractions. Write $<$, $>$, or $=$ for each.

16. $\frac{1}{3}$ _____ $\frac{5}{9}$

17. $\frac{2}{5}$ _____ $\frac{3}{10}$

18. $\frac{5}{8}$ _____ $\frac{3}{4}$

19. $\frac{6}{10}$ _____ $\frac{3}{5}$

Name _____

Circles

For 1–6 use the circle at the right. Name the given parts of the circle.

- | | |
|--------------------------------------|--|
| 1. center _____ | 2. diameters _____ |
| 3. radii _____ | 4. arcs _____ |
| 5. chords other than diameters _____ | 6. How many sectors are shown in the circle? _____ |

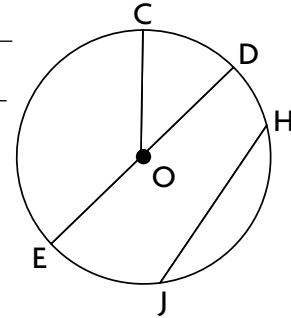

For 7–12 complete the sentence by using *must*, *can*, or *cannot*.

- Two radii of the same circle _____ be equal in length.
- An arc _____ pass through the center of a circle.
- Two chords of the same circle _____ be equal in length.
- A chord drawn through the center of a circle _____ be the longest line segment that can be drawn in the circle.
- Two sectors of a circle _____ be equal in area.
- As the size of a circle increases, the relationship between the radius and the diameter _____ change.

Mixed Review

Evaluate the expression.

- | | |
|-----------------------------------|--|
| 13. $-2 + 6^2 - 3 + 9$ _____ | 14. $9 \div 3 \times 4 + (10 - 6)$ _____ |
| 15. $2^3 + 4 \times -5 - 1$ _____ | 16. $(4 \times 6) - (-8 \times 3)$ _____ |

Find the measure of each angle.

- | | | |
|--|--|---|
| 17. The complement of the angle is 18° .
_____ | 18. The supplement of the angle is 73° .
_____ | 19. The supplement of the angle is 126° .
_____ |
|--|--|---|

Name _____

Types Solid Figures

Classify the figure. Is it a polyhedron?

1.

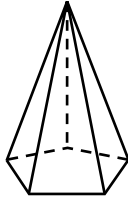

2.

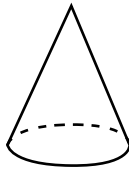

3.

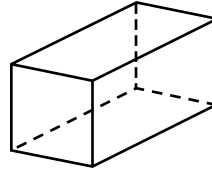

4.

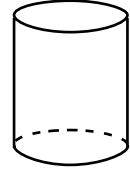

Write *true* or *false* for each statement. Rewrite each false statement as a true statement.

5. A cylinder has one base.

6. A cone has one flat surface.

7. A cube has 8 faces

8. A square pyramid is a polyhedron.

9. A triangular prism has 2 congruent bases.

10. The faces of a square pyramid are squares.

Mixed Review

Solve and check.

11. $a - 40 = 21$

12. $b - 3 = 18$

13. $75 = c - 48$

14. $-16 = d - 9$

15. $14\frac{1}{2} = e - 11\frac{1}{2}$

16. $-7.3 = f - 4$

Write the equal factors. Then find the value.

17. 7^3

18. 9^2

19. 4^4

Name _____



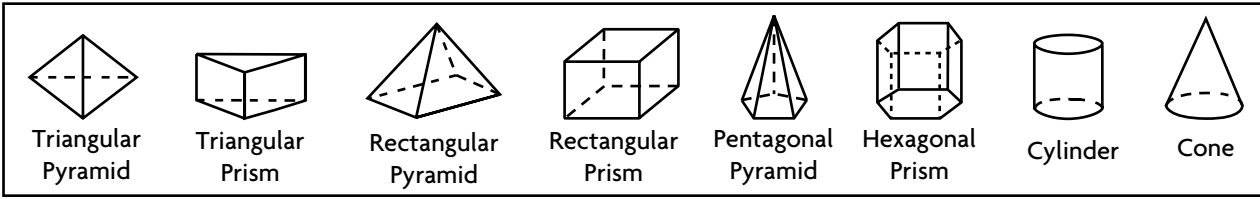

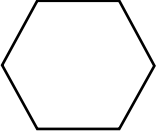
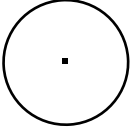
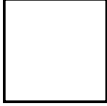
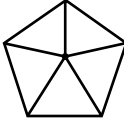
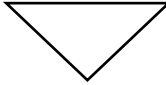

Different Views of Solid Figures

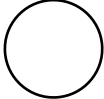
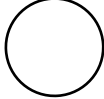
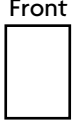

Name each solid that has the given top view. Refer to the solids in the box above.

- | | | | | | | | | | |
|-------|---|----|---|----|---|----|--|----|---|
| 1. |  | 2. |  | 3. |  | 4. |  | 5. |  |
| _____ | | | | | | | | | |
| _____ | | | | | | | | | |

Name the solid figure that has the given views.

- | | | |
|---|---|---|
| <p>6.</p> <div style="display: flex; justify-content: space-around;"> <div style="text-align: center;"> <p>Top</p>  </div> <div style="text-align: center;"> <p>Bottom</p>  </div> </div> <div style="text-align: center; margin-top: 10px;"> <p>Front</p>  </div> | <p>7.</p> <div style="text-align: center;"> <p>Top</p>  </div> <div style="display: flex; justify-content: space-around; margin-top: 10px;"> <div style="text-align: center;"> <p>Front</p>  </div> <div style="text-align: center;"> <p>Side</p>  </div> </div> | <p>8.</p> <div style="text-align: center;"> <p>Top</p>  </div> <div style="display: flex; justify-content: space-around; margin-top: 10px;"> <div style="text-align: center;"> <p>Front</p>  </div> <div style="text-align: center;"> <p>Bottom</p>  </div> </div> |
| _____ | | |

Mixed Review

9. $\sqrt{100} \times (4 - 3^2) + 9^2$

10. $(8 - 3)^2 - (\sqrt{49} + \sqrt{4})$

Write each rational number in the form $\frac{a}{b}$.

11. 4.75

12. $6\frac{1}{8}$

13. -6.3

14. $10\frac{1}{2}$

Name _____

Problem-Solving Strategy: Solve a Simpler Problem

Solve by first solving a simpler problem.

1. Jon is building models of edible prisms. He uses gumdrops for vertices and licorice for edges. How many gumdrops and pieces of licorice will he need to make a prism whose base has 8 sides?

2. Carol wants to make a model of a prism whose base has 9 sides. She will use balls of clay for the vertices and straws for the edges. How many balls of clay and straws will she need? How many faces will her prism have?

3. Chloe used 30 toothpicks as edges to make a model for a prism. How many sides did the base of her prism have? How many vertices?

4. Dan used 12 balls of clay as vertices to make a model for a prism. How many sides did the base of his prism have? How many edges?

5. Marty built a model of a solid figure. It has 6 vertices and 9 edges. It has 5 faces. What is this figure?

6. Nancy built a model of a solid figure. It has 5 vertices and 8 edges. It has 5 faces. What is this figure?

Mixed Review

For 7–12, use the figure at the right. Find the measure of each angle.

7. $\angle BCO$ _____
8. $\angle BOC$ _____
9. $\angle ECD$ _____
10. $\angle COD$ _____
11. $\angle BOE$ _____
12. $\angle ODC$ _____

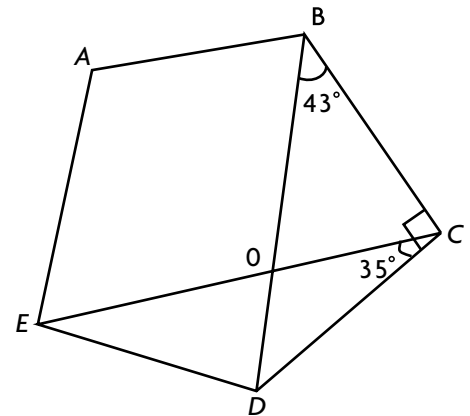

Find the sum or difference.

13. $306 + 1,229 + 558 + 74$ _____
14. $45,923 + 7,192 + 19,537$ _____
15. $727,401 - 204,854$ _____
16. $93,144 - 3,019$ _____

Ratios and Rates

Write two equivalent ratios.

1. $\frac{4}{6}$

2. $\frac{12}{28}$

3. $\frac{5}{20}$

4. $\frac{2}{18}$

5. $\frac{7}{49}$

6. $\frac{2}{5}$

Write each ratio in fraction form. Then find the unit rate.

7. 7 apples for \$1.00

8. \$0.06 per page

9. 24 people in 6 cars

10. 65 mi per 3 gal

11. 5 CDs for \$49

12. \$20 per dozen tarts

For Exercises 13–14, use the figure at the right.

13. Find the ratio of unshaded sections to shaded sections. Then write three equivalent ratios.

14. Find the ratio of shaded sections to all the sections. Then write three equivalent ratios.

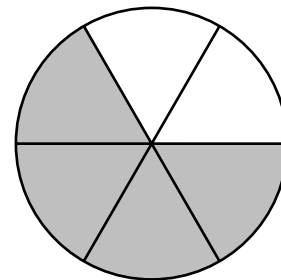

Find the missing term that makes the ratios equivalent.

15. $\frac{3}{7}$, $\frac{\square}{14}$ _____

16. 7 to 5, \square to 15 _____

17. 15:5, 3: \square _____

Mixed Review

Find the quotient. Write the answer in simplest form.

18. $\frac{7}{8} \div \frac{3}{4}$ _____

19. $\frac{2}{3} \div \frac{1}{5}$ _____

20. $5 \div \frac{1}{4}$ _____

21. $2\frac{1}{2} \div \frac{3}{8}$ _____

Compare the fractions. Write $<$, $>$, or $=$ for each.

22. $-\frac{1}{3}$ _____ $-\frac{2}{3}$

23. $\frac{5}{8}$ _____ 0.75

24. 0.34 _____ -1

25. 0.25 _____ $\frac{1}{4}$

Problem-Solving Strategy**Write an Equation**

Solve the problem by writing an equation.

- | | |
|---|---|
| <p>1. A dripping faucet wastes 3 cups of water in 24 hr. How much water is wasted in 56 hours?</p> <p>_____</p> | <p>2. A map uses the scale of 3 cm for every 10 km. If the map shows a distance of 12 cm, what is the actual distance?</p> <p>_____</p> |
| <p>3. A pump empties the pool at the rate of 1,000 gal every 4 hours. How long does it take to pump out 20,000 gallons?</p> <p>_____</p> | <p>4. Tom drinks 8 oz of water for every 3 miles he bikes. After 21 miles, how much water did he drink?</p> <p>_____</p> |
| <p>5. A punch consists of 2 parts ginger ale and 3 parts orange juice. If the punch bowl contains 8 c of ginger ale, how many cups of punch are in the bowl?</p> <p>_____</p> | <p>6. A 5-lb bag of apples contains 12 apples. What will a bag of 40 apples weigh?</p> <p>_____</p> |
| <p>7. Jane can iron 4 shirts in 1 hr. How long will it take her to iron 10 shirts?</p> <p>_____</p> | <p>8. Sol is going on a trip of 275 mi. If he drives a steady 50 mi per hr, how long should the trip take?</p> <p>_____</p> |

Mixed Review

Find the quotient. Write the answer in simplest form.

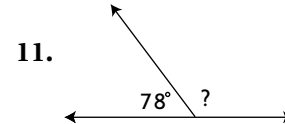
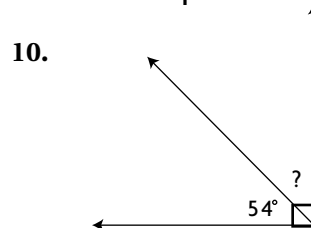
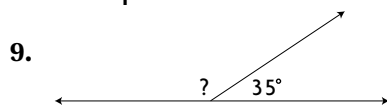
Evaluate the expression for $m = 5$ and $n = 2$.

12. $m - n^2 + 18 \div 3$ _____

13. $30 \div (m^2 - 10) + 6 \times n$ _____

14. $n \times 8(m - 2) - 4^2$ _____

15. $10 - (4 - n) \div (m + 3)$ _____

Name _____

Algebra: Ratios and Similar Figures

Name the corresponding sides and angles. Write the ratio of the corresponding sides in simplest form.

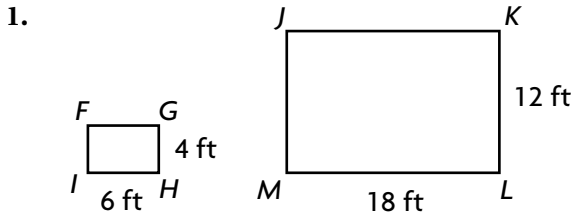

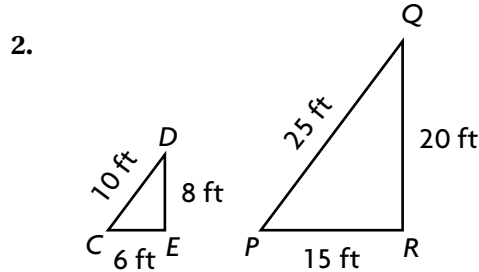

Tell whether the figures in each pair are similar. Write *yes* or *no*. If you write *no*, explain.

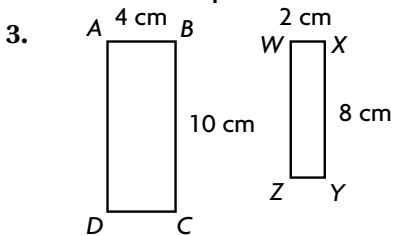

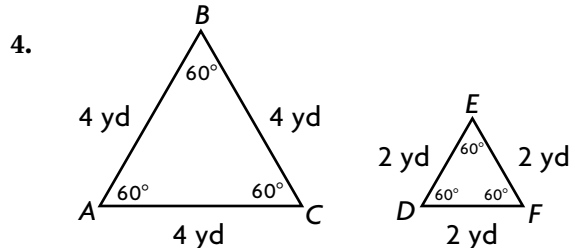

The figures in each pair are similar. Find the missing measures.

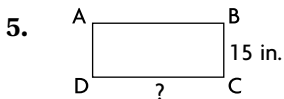

6.

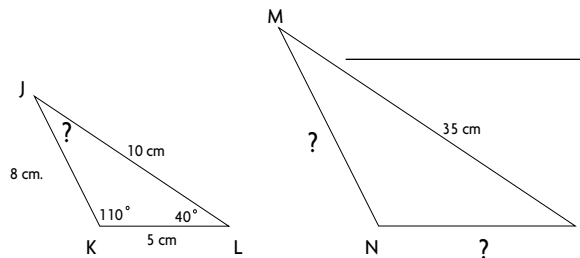

Mixed Review

Write the mixed number as a fraction.

7. $7\frac{27}{3}$ _____

8. $2\frac{8}{9}$ _____

9. $10\frac{1}{6}$ _____

10. $5\frac{4}{5}$ _____

Find the difference.

11. $+12 - -7\frac{7}{7}$ _____

12. $-4 - -8$ _____

13. $-21 - +5$ _____

14. $-15 - -8$ _____

Name _____

Algebra: Proportions and Similar Figures

Write a proportion. Then find the unknown length. The figures in each pair are similar.

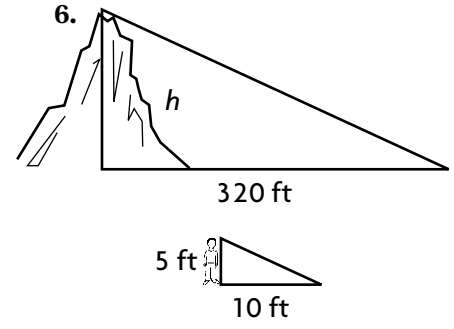
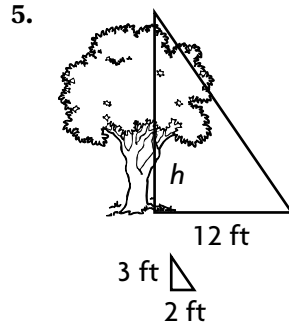
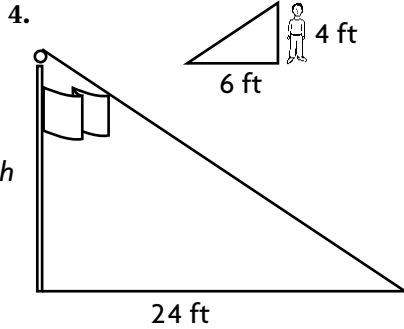
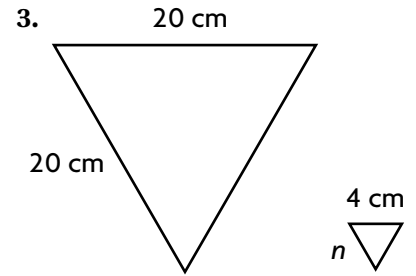
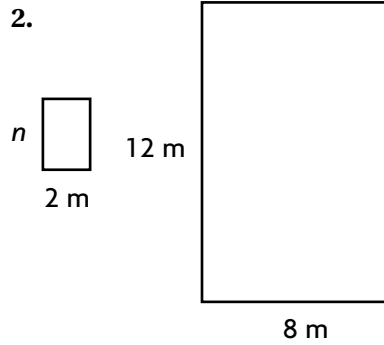
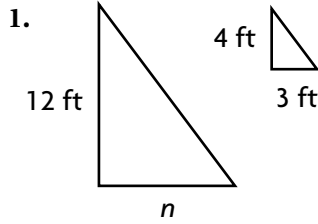

Mixed Review

Solve and check.

7. $n + 5.5 = 23.1$

8. $4\frac{1}{2} = k + \frac{3}{4}$

9. $28 + w = 104$

Find the LCM of each pair of numbers.

10. 4, 15 _____

11. 7, 9 _____

12. 6, 16 _____

13. 12, 25 _____

Algebra: Scale Drawings

Find the missing dimension.

1. scale: 1 in.:8 ft
drawing length: 3 in.

actual length: _____ ft

3. scale: 1 cm = 15 km

drawing length: _____ cm

actual length: 135 km

5. scale: 1 mm: 12 m
drawing length: 9 mm

actual length: _____ m

7. scale: 3 cm = 10 km

drawing length: _____ cm

actual length: 65 km

9. scale: 10 in.:88 yd
drawing length: 2 in.

actual length: _____ yd

11. scale: 1 mm = 25 m

drawing length: _____ mm

actual length: 350 m

2. scale: 1 in.:3 ft

drawing length: _____ in.

actual length: 12 ft

4. scale: 4 cm = 1 mm
drawing length: 1 cm

actual length: _____ mm

6. scale: 5 in.: 35 yd
drawing length: _____ in
actual length: 7 yd

8. scale: 8 cm = 3 mm
drawing length: 4 cm

actual length: _____ mm

10. scale: 1 in.:12 ft
drawing length: _____ in.
actual length: 144 ft

12. scale: 1 cm = 3 km
drawing length: 15 cm

actual length: _____ km

Mixed Review

Find the measure of the missing angle and classify the triangle.

13.

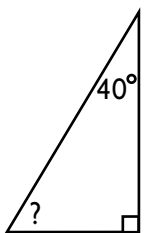

14.

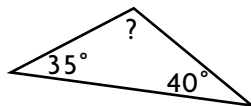

15.

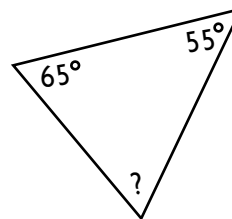
Simplify the expression, then evaluate for $x = -5$.

16. $2x + x^2 - 7 - 8x$

17. $5x + 15 + 3x - 2$

18. $59 + 7x - 6 + 4x$

Algebra: Maps

The map distance is given. Find the actual distance. The scale is

1 in. = 20 mi.

1. 4 in.

2. 20 in.

3. $1\frac{1}{2}$ in.

4. 6 in.

5. 18 in.

6. $2\frac{1}{2}$ in.

7. $3\frac{1}{2}$ in.

8. $5\frac{1}{2}$ in.

The actual distance is given. Find the map distance. The scale is

1 in. = 20 mi.

9. 250 mi

10. 100 mi

11. 150 mi

12. 170 mi

13. 500 mi

14. 190 mi

15. 220 mi

16. 580 mi

Mixed Review

Find the mean, median, and mode.

17. 27, 19, 24, 29, 18, 25
29, 23, 28

18. 39, 51, 45, 69, 22, 41, 33,
57, 30

19. 99, 102, 97, 110, 97, 93,
98, 104, 108

Place the decimal point in the product.

20. $27.95 \times 4.3 = 120185$

21. $7.16 \times 1.82 = 130312$

22. $2.709 \times 0.356 = 964404$

Percent

Write the percent that is shaded.

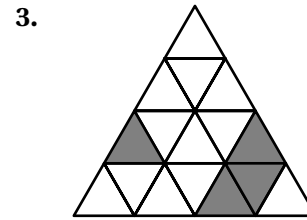
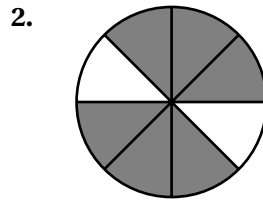
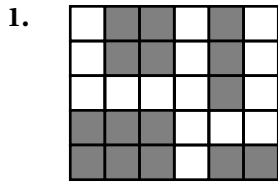

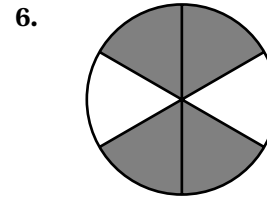
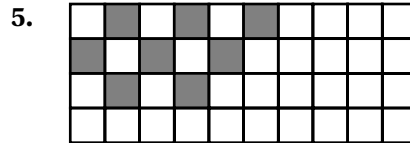
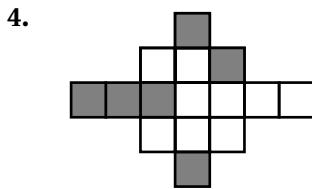

Write as a percent.

7. $\frac{87}{100}$ _____ 8. $\frac{6}{25}$ _____ 9. $\frac{9}{10}$ _____ 10. $\frac{120}{100}$ _____
 11. $\frac{13}{20}$ _____ 12. $\frac{1}{10}$ _____ 13. $\frac{7}{25}$ _____ 14. $\frac{85}{50}$ _____

Compare. Write $>$, $<$, or $=$.

15. 2.3% _____ 23% 16. 10% _____ 7% 17. 5% _____ 0.5%
 18. 0.79% _____ 7.9% 19. 125% _____ 12.5% 20. 8.00% _____ 8%

Mixed Review

Write the ratio in fraction form. Then find the unit rate.

21. 120 swimmers for 6 lifeguards _____
 22. 385 miles in 7 hours _____
 23. \$1.92 for 8 oz _____
 24. \$5.40 for a dozen muffins _____

Write the prime factorization in exponent form.

25. 63 _____ 26. 144 _____ 27. 230 _____

Percents, Decimals, and Fractions

Write as a percent.

1. 0.7 _____

2. 0.18 _____

3. 0.84 _____

4. 0.41 _____

5. $\frac{3}{5}$ _____

6. $\frac{17}{100}$ _____

7. $\frac{5}{8}$ _____

8. $\frac{8}{25}$ _____

Write each percent as a fraction or mixed number in simplest form.

9. 75% _____

10. 30% _____

11. 55% _____

12. 240% _____

13. 6% _____

14. 56% _____

15. 105% _____

16. $12\frac{1}{2}\%$ _____

Write each percent as a decimal.

17. 37% _____

18. 9% _____

19. 0.05% _____

20. 321% _____

Compare. Write $>$, $<$, or $=$.

21. $\frac{1}{8}$ _____ 8%

22. 23% _____ 2.3

23. 30% _____ $\frac{1}{3}$

Mixed Review

Find the quotient. Write the answer in simplest form.

24. $5 \div \frac{3}{8}$

25. $6\frac{1}{3} \div \frac{2}{5}$

26. $1\frac{1}{2} \div 3\frac{1}{3}$

27. $2\frac{3}{5} \div \frac{1}{8}$

For 28–30, use the figure at the right.

28. Name two angles adjacent to $\angle JOK$.

29. Name an angle vertical to $\angle KOL$.

30. Name two angles supplementary to $\angle MON$.

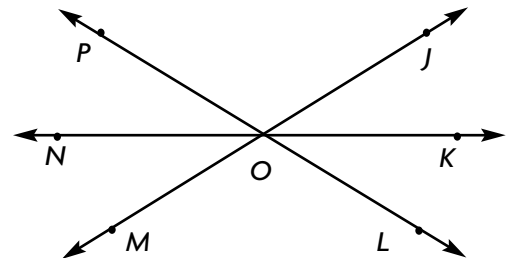

Name _____

Estimate and Find Percent of a Number

Use a fraction in simplest form to find the percent of the number.

1. 10% of 8 2. 25% of 60 3. 50% of 50 4. 70% of 90 5. 80% of 70

Use a decimal to find the percent of the number.

6. 15% of 8 7. 35% of 45 8. 55% of 92 9. 82% of 70 10. 93% of 24

Use the method of your choice to find the percent of the number.

11. 52% of 40 12. 96% of 84 13. 81% of 34 14. 12% of 300 15. 67% of 200

16. 4.5% of 90 17. 110% of 30 18. 140% of 100 19. 200% of 250 20. 400% of 80

Estimate a 15% tip for each amount.

21. \$12.00 22. \$5.50 23. \$23.75 24. \$39.50 25. \$94.80

Each proportion shows the percent of a number, n .

What is the percent? What is the percent of the number?

26. $\frac{20}{100} = \frac{n}{40}$ 27. $\frac{5}{100} = \frac{n}{30}$ 28. $\frac{n}{150} = \frac{12}{100}$

Mixed Review

Solve and check.

29. $5n = 45$ 30. $\frac{m}{3} = 12$ 31. $99 = -9k$ 32. $21.4 = \frac{a}{6.3}$

Find the sum or difference. Write the answer in simplest form.

33. $\frac{5}{8} - \frac{1}{4}$ 34. $\frac{2}{5} + \frac{1}{3}$ 35. $\frac{5}{7} - \frac{1}{3}$ 36. $\frac{3}{4} + \frac{1}{10}$

Name _____

Discount and Sales Tax

Find the sale price.

1. regular price:

\$18.50

Discount 20%

2. regular price:

\$35.00

25% off

3. regular price:

\$45.50

SAVE 50%

4. regular price:

\$23.60

SALE 80% off

5. regular price \$79.50

discount rate: 15%

6. regular price \$153.99

discount rate: 10%

7. regular price \$750.00

discount rate: 18%

Find the regular price.

8. saleprice \$47.60

discount rate: 30%

9. saleprice \$24.70

discount rate: 5%

10. saleprice \$239.20

discount rate: 20%

Find the sale tax for the given price. Round to the nearest cent.

11. \$30.00

tax: 8%

12. \$15.80

tax: 11%

13. \$654.00

tax: 7.5%

14. \$1,842.00

tax: 4%

Find the total cost of the purchase. Round to the nearest cent.

15. price: \$79.50

tax: 8%

16. price: \$129.95

tax: 6%

17. price: \$405.00

tax: 9%

18. price: \$3,385.00

tax: 5.5%

Mixed Review

Find the quotient.

19. $36 \div^{-} 4$ _____

20. $^{-} 39 \div 3$ _____

21. $^{-} 60 \div^{-} 15$ _____

22. $81 \div^{-} 9$ _____

Compare the fractions. Write $>$, $<$, or $=$.

23. $\frac{2}{3}$ ○ $\frac{6}{8}$

24. $\frac{10}{12}$ ○ $\frac{5}{8}$

25. $\frac{2}{7}$ ○ $\frac{3}{5}$

26. $\frac{8}{9}$ ○ $\frac{13}{14}$

Name _____

Simple Interest

Find the simple interest.

1. principal: \$8,000
rate: 5%
time: 3 years

2. principal: \$1,500
rate: 7.2%
time: 10 years

3. principal: \$22,500
rate: 4.8%
time: 13 years

Find the simple interest.

	Principal	Yearly Rate	Interest for 1 Year	Interest for 2 Years
4.	\$80	3%		
5.	\$150	4.5%		
6.	\$340	6%		
7.	\$600	5.2%		
8.	\$1,400	7.9%		
9.	\$5,500	9%		
10.	\$7,500	8.5%		
11.	\$10,000	9.6%		
12.	\$11,350	9.8%		
13.	\$12,975	9.5%		

Mixed Review

Convert the temperature to degrees Fahrenheit. Write the answer as a decimal.

14. 50°C

15. 10°C

16. 93°C

17. 23°C

18. 35°C

Find the sum.

19. $+9 + ^{-}6$ _____

20. $^{-}4 + ^{-}7$ _____

21. $^{-}12 + ^{+}8$ _____

22. $^{-}20 + ^{+}14$ _____

23. $^{+}3 + ^{-}18$ _____

24. $^{-}6 + ^{-}2$ _____

25. $^{-}36 + ^{+}36$ _____

26. $^{+}30 + ^{-}15$ _____

27. $^{-}5 + ^{-}8$ _____

Name _____

Theoretical Probability

Use the spinner at the right to find each probability. Express each answer as a fraction, decimal, and percent.

- 1. $P(M)$ _____
- 2. $P(H)$ _____
- 3. $P(J)$ _____
- 4. $P(T)$ _____
- 5. $P(A)$ _____
- 6. $P(M \text{ or } A)$ _____
- 7. $P(T \text{ or } H)$ _____
- 8. $P(M, A, \text{ or } T)$ _____

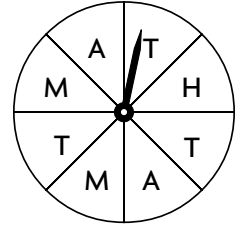

A bag contains 5 blue, 3 red, and 2 green pencils. You choose one pencil without looking. Find each probability. Tell how the event is likely to occur. Write *impossible*, *unlikely*, *likely*, *very likely*, or *certain*.

- 9. $P(\text{pink})$ _____
- 10. $P(\text{blue})$ _____
- 11. $P(\text{green})$ _____
- 12. $P(\text{blue or red})$ _____

Cards numbered 2, 2, 2, 3, 4, 4, 5, and 5 are placed in a box. You choose one card without looking. Compare the probabilities. Write $<$, $>$, or $=$.

- 13. $P(2) \bigcirc P(4)$
- 14. $P(4) \bigcirc P(5)$
- 15. $P(3 \text{ or } 5) \bigcirc P(2, 3, \text{ or } 5)$

For Exercises 16–18, use the figure at the right. Find each probability.

- 16. $P(\text{shaded square})$ _____
- 17. $P(\text{striped or white square})$ _____
- 18. $P(\text{shaded or striped square})$ _____

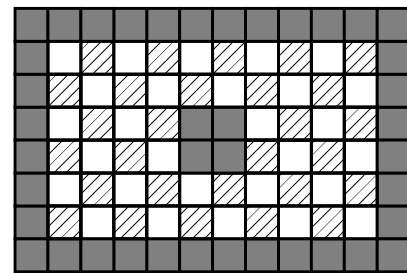

Mixed Review

Evaluate the expression for $x = -3$, -1 , and 2 .

- 19. $-3x + 5$ _____
- 20. $x^2 - 4x$ _____
- 21. $7(2x + 1)$ _____
- 22. $x^2(6 - x)$ _____

Write the fraction as a percent.

- 23. $\frac{3}{4}$ _____
- 24. $\frac{3}{10}$ _____
- 25. $\frac{2}{25}$ _____
- 26. $\frac{6}{5}$ _____

Name _____

Problem-Solving Skill: Too Much or Too Little Information

Write if each problem has *too much*, *too little*, or *the right amount* of information. Then solve the problem if possible, or write what information is needed to solve it.

- | | |
|--|--|
| <p>1. It costs \$1 to buy a drink from a machine. The machine has water, 3 types of juice, and 5 different sodas. If Caryn pushes one of the buttons without looking, what is the probability that she will get one of the juices?</p> <p>_____</p> | <p>2. Manny is in line at the Multiplex Theater. Of all the movies playing, there are 3 that Manny wants to see. If he buys a ticket without asking for a particular movie, what is the probability that he will get a ticket for a movie he wants to see?</p> <p>_____</p> |
| <p>3. Mr. Irving is playing a game at a charity carnival. He pays \$15 for a chance to play. To find out what he has won, he reaches into a bag containing a \$1 bill, a \$5 bill, a \$10 bill, a \$20 bill, and a \$50 bill. What is the probability that Mr. Irving will win more than the game cost?</p> <p>_____</p> | <p>4. Jessie ordered several books from an on-line store. When they arrived, she opened the carton, examined both science fiction books and the other novels. If she then randomly chose a book to read, what is the probability she chose on of the science fiction books?</p> <p>_____</p> |
| <p>5. Leah was trying to guess the year Ali was born. She knew it was anywhere from 1980 through 1985. Her first guess was 1982. It was incorrect. What is the probability that Leah guessed correctly on her next try?</p> <p>_____</p> | <p>6. Albert paid \$8.95 for an almanac. He found out that in his city it rains an average of 75 days each year and snows an average of 15 days each year. What is the ratio of rainy days to snowy days?</p> <p>_____</p> |

Mixed Review

Use a decimal to find the percent of the number.

7. 20% of 15

8. 45% of 50

9. 90% of 70

10. 65% of 30

Find the difference

11. $+3 - -7$

12. $+8 - +15$

13. $-17 - +5$

14. $-14 - -9$

Name _____

Experimental Probability

Adam tossed a coin 50 times. For Exercises 1–2, use the table at the right to find the experimental probability.

Coin	Heads	Tails
Toss	22	28

- P(Heads) _____
- P(Tails) _____
- What is the theoretical probability of getting heads? _____

Sarah rolled a number cube numbered 1 to 6. The table below shows the results of rolling the cube 50 times. Use the results in the table to find the experimental probability.

Number	1	2	3	4	5	6
Times rolled	6	11	5	10	16	2

- P(3) _____
- P(4 or 5) _____
- P(1 or 2) _____
- P(5) _____
- P(1) _____
- P(6) _____
- P(1 or 3) _____
- P(3 or 6) _____
- P(not 4) _____
- What is the theoretical probability for each number? _____

Mixed Review

Multiply. Write the answer in simplest form.

14. $\frac{3}{4} \times \frac{2}{3}$

15. $\frac{1}{2} \times \frac{5}{6}$

16. $\frac{3}{8} \times \frac{4}{9}$

17. $\frac{5}{12} \times \frac{3}{10}$

Find the sum or difference. Write the answer in simplest form.

18. $1\frac{1}{2} + 3\frac{3}{8}$ _____

19. $5\frac{7}{8} - 2\frac{1}{4}$ _____

20. $\frac{7}{9} + 3\frac{2}{3}$ _____

21. $4\frac{2}{5} - 1\frac{3}{10}$ _____

22. $6\frac{1}{6} + 7\frac{3}{4}$ _____

23. $8\frac{5}{12} - 3\frac{1}{3}$ _____

Name _____

Problem Solving Strategy: Make an Organized List

Solve the problem by making an organized list.

- | | |
|---|---|
| <p>1. Mr. Perez is planning a trip. He can leave on Monday, Wednesday, or Friday, at 8:00 A.M., 10:30 A.M., 2:00 P.M., or 4:30 P.M. How many choices does Mr. Perez have?</p> | <p>2. Len is going on vacation. He has 1 jacket, 2 sweaters, and 4 shirts. How many different outfits can Len make if each outfit consists of a jacket, sweater, and shirt?</p> |
|---|---|

- | | |
|---|--|
| <p>3. The 14 members of the bicycle team want to put 2-digit numbers on the backs of their jerseys. They decided to use only the digits 2, 4, 6, 8. Can each team member have a different number? How many possible combinations are there?</p> | <p>4. Twelve members of the science club are planning their next field trip. They can take the trip in May or June. They can visit a science museum, bird sanctuary, zoo, or planetarium. How many different field trips involving 1 place and 1 month are possible?</p> |
|---|--|

- | | |
|--|---|
| <p>5. Ben is planning a hike to Eagle Mountain, Crystal Lake, and Cedar Falls. He cannot decide in which order to visit them. How many choices does he have?</p> | <p>6. Nina found jackets in blue, green, and red. She found scarves in yellow, beige, and navy. She wants to buy a jacket and scarf. How many combinations can she choose from?</p> |
|--|---|

Mixed Review

A number cube is numbered 2, 3, 5, 8, 9, 9. Find each probability.

7. $P(5)$ _____ 8. $P(9)$ _____ 9. $P(\text{even})$ _____ 10. $P(\text{not } 9)$ _____

Write a proportion. Then find the unknown length. The figures are similar.

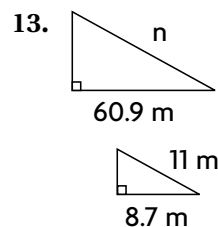
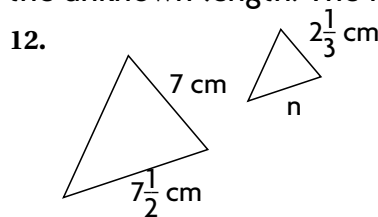
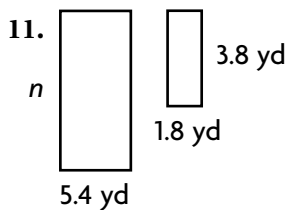

Compound Events

Draw a tree diagram or make a table to find the number of outcomes for each situation.

1. spinning a pointer on a spinner labeled 1 to 4 and tossing a coin

3. a choice of either a red, blue, or green shirt and a black, gray, or brown jacket

2. a choice of 3 cards, 2 envelopes, and 2 stickers

4. a choice of 4 sandwiches, 2 drinks, and 2 desserts

Use the Fundamental Counting Principle to find the number of outcomes for each situation.

5. a choice of 3 juices, 2 muffins, and 3 sandwiches

7. tossing a coin and rolling 2 number cubes labeled 1 to 6.

9. A Chinese restaurant offers 25 main dishes, 3 kinds of rice, and 3 different beverages. If the restaurant is open every day of the year, is it possible to eat a different meal there every day for a year? Explain.

6. a choice of 3 beverages, 2 snacks, and 4 sandwiches

8. a choice of 4 shirts, 4 ties, 3 trousers, and 3 belts

10. Mr. Samson is buying 3 houses. One will be in either Boston or New York. One will be in either Los Angeles or Dallas. One will be in either Chicago, Denver, or Santa Fe. How many combinations are possible?

Mixed Review

Write each percent as a decimal.

11. 28% _____ 12. 5% _____ 13. 163% _____ 14. 91% _____

Find the measure of the third angle and classify the triangle.

15. $\angle 1 = 36^\circ$; $\angle 2 = 18^\circ$ 16. $\angle 1 = 53^\circ$; $\angle 2 = 37^\circ$ 17. $\angle 1 = 68^\circ$; $\angle 2 = 59^\circ$

Name _____

Independent and Dependent Events

Write *independent* or *dependent* to describe the event.

- | | |
|---|--|
| <p>1. roll two number cubes two times</p> <p>_____</p> | <p>2. select a lettered tile from a box, do not replace it, select another tile</p> <p>_____</p> |
| <p>3. select a coin from a jar, do not replace it, select another coin</p> <p>_____</p> | <p>4. select a marble from a bag, replace it, select another marble</p> <p>_____</p> |

Without looking, you take a card out of a jar and replace it before selecting again. Find the probability of each event. Then find the probability assuming the card is not replaced after each selection.



- | | | | |
|----------------------------|--------------------------|----------------------------|---------------------------|
| 5. $P(5, 6)$ | 6. $P(6, 8)$ | 7. $P(5, 7 \text{ or } 8)$ | 8. $P(6, \text{ not } 5)$ |
| _____ | _____ | _____ | _____ |
| 9. $P(6, 7 \text{ or } 8)$ | 10. $P(5, \text{ even})$ | 11. $P(7, 7)$ | 12. $P(7, 6, 5)$ |
| _____ | _____ | _____ | _____ |
| 13. $P(6, \text{ odd})$ | 14. $P(5, 8, 5)$ | 15. $P(5, 6, 7)$ | 16. $P(5, 5)$ |
| _____ | _____ | _____ | _____ |

Mixed Review

Use the formula $d = rt$ to complete.

Write the fraction in simplest form.

- | | | |
|--|--|---|
| <p>17. $d = 858 \text{ cm}$
$r = 55 \text{ cm per second}$</p> <p>$t =$ _____</p> | <p>18. $r = 48 \text{ mi per hr}$
$t = 6.5 \text{ hr}$</p> <p>$d =$ _____</p> | <p>19. $d = 423 \text{ m}$
$t = 18 \text{ min}$</p> <p>$r =$ _____</p> |
| 20. $\frac{25}{150}$ _____ | 21. $\frac{42}{210}$ _____ | 22. $\frac{27}{72}$ _____ |
| | | 23. $\frac{39}{52}$ _____ |

Name _____

Make Predictions

The results of a survey of 600 randomly selected teenagers in California indicate that 150 of them use their computers at least 2 hr a day.

1. What is the probability that a randomly selected teenager in California uses the computer at least 2 hr a day?

2. Out of 5,500 California teenagers, predict how many would indicate that they use their computers at least 2 hr a day.

3. In a sample of 800 bicycles, the quality control department found that 32 of them were defective. If the company manufactures 8,000 bicycles, about how many of them are defective?

4. In a sample of 700 phones, the quality control department found 21 of them were defective. If the company manufactures 14,000 phones, about how many of them are defective?

The table shows the favorite sports indicated by a random sample of 150 sixth graders from Glenville Middle School. Use the table for Exercises 5 and 6.

5. If there are 360 sixth graders at Glenville Middle School, about how many will prefer baseball? soccer?

6. If there are 450 sixth graders at Glenville Middle School, about how many will prefer a sport other than baseball?

Favorite Sports

Sport	Number of Students
baseball	45
basketball	20
soccer	25
hockey	10
track	15
football	35

Mixed Review

Find the difference.

7. $+8 - +9$ _____
8. $-5 - +3$ _____
9. $+12 - -4$ _____
10. $-6 - -9$ _____

Find the LCM of each pair of numbers.

11. 5, 13 _____
12. 12, 18 _____
13. 9, 15 _____
14. 8, 22 _____

Name _____

Customary Measurements

Use a proportion to convert to the given unit.

- | | | |
|---------------------------------|-----------------------------------|----------------------------------|
| 1. 80 fl oz = _____ c | 2. 18 pt = _____ qt | 3. 510 ft = _____ yd |
| 4. 720 in. = _____ yd | 5. 5 months \approx _____ weeks | 6. 6 c = _____ fl oz |
| 7. 3 gal = _____ qt | 8. 6 T = _____ lb | 9. 32 fl oz = _____ c |
| 10. 5 mi = _____ ft | 11. 44 qt = _____ gal | 12. 10 pt = _____ c |
| 13. 157 ft = _____ yd _____ ft | 14. 220 in. = _____ ft _____ in. | 15. $5\frac{2}{3}$ yd = _____ ft |
| 16. $5\frac{1}{2}$ T = _____ lb | 17. $6\frac{1}{4}$ ft = _____ in. | 18. $7\frac{1}{2}$ ft = _____ yd |
| 19. 325 ft = _____ yd _____ ft | 20. $3\frac{3}{4}$ yd = _____ ft | 21. 15 gal = _____ qt |

Compare. Write $<$, $>$, or $=$ for \bigcirc .

- | | | |
|--------------------------------------|-------------------------------------|--|
| 22. 8,500 lb \bigcirc 4 T
_____ | 23. 25 yd \bigcirc 75 ft
_____ | 24. 9 days \bigcirc 225 hrs
_____ |
| 25. 16 c \bigcirc 4 qt
_____ | 26. 5 gal \bigcirc 30 pt
_____ | 27. 12 ft \bigcirc 120 in.
_____ |

Mixed Review

Use inverse operations to solve. Check your solution.

- | | | |
|-------------------------------|--------------------------------|------------------------|
| 28. $6x = 84$ _____ | 29. $\frac{w}{11} = 6$ _____ | 30. $3.5m = 14$ _____ |
| 31. $\frac{c}{8} = 4.7$ _____ | 32. $6.3 = \frac{h}{20}$ _____ | 33. $9.9 = 1.8r$ _____ |

Find the product.

- | | | | |
|---------------------------------|-----------------------------|----------------------------|----------------------------------|
| 34. $^{-}11 \times ^{-}5$ _____ | 35. $18 \times ^{-}6$ _____ | 36. $^{-}7 \times 8$ _____ | 37. $^{-}14 \times ^{-}21$ _____ |
|---------------------------------|-----------------------------|----------------------------|----------------------------------|

Name _____

Metric Measurements

Complete the pattern.

1. 1 L = _____ cL

2. 1,000 mg = _____ g

3. 1 m = _____ km

0.1 L = _____ cL

100 mg = _____ g

10 m = _____ km

0.01 L = _____ cL

10 mg = _____ g

100 m = _____ km

1 mg = _____ g

1,000 m = _____ km

Use a proportion to convert to the given unit.

4. 40 g = _____ kg

5. 300 km = _____ m

6. 9 kL = _____ L

7. 6 kL = _____ dL

8. 300 cm = _____ dm

9. 50 dL = _____ cL

10. 12 kL = _____ L

11. 28 g = _____ mg

12. 8 km = _____ m

13. 2.2 g = _____ cg

14. 7 dm = _____ m

15. 5.5 cg = _____ dg

Compare. Write $, < >$, or $=$ for \bigcirc .

16. 600 mm \bigcirc 6 m

17. 80 km \bigcirc 80,000 m

18. 4,000 mL \bigcirc 4 L

19. 2.5 kg \bigcirc 25,000 mg

20. 50 kL \bigcirc 50,000 L

21. 14,500 mg \bigcirc 145 g

Mixed Review

Find the quotient.

22. $\bar{8}5 \div \bar{5}$

23. $\bar{4}8 \div 8$

24. $162 \div \bar{9}$

25. $\bar{1}32 \div \bar{1}2$

Find the difference. Write the answer in simplest form.

26. $7\frac{1}{2} - 6\frac{1}{3}$

27. $5\frac{5}{8} - 3\frac{3}{4}$

28. $10\frac{1}{6} - 5\frac{7}{8}$

29. $15\frac{1}{3} - 12\frac{4}{5}$

Name _____

Relate Customary and Metric

Use a proportion to convert to the given unit.

1. $4 \text{ ft} \approx \underline{\quad? \quad} \text{ cm}$

2. $16 \text{ yd} \approx \underline{\quad? \quad} \text{ m}$

3. $12 \text{ qt} \approx \underline{\quad? \quad} \text{ L}$

4. $30 \text{ lb} \approx \underline{\quad? \quad} \text{ kg}$

5. $16 \text{ L} \approx \underline{\quad? \quad} \text{ qt}$

6. $64 \text{ cm} \approx \underline{\quad? \quad} \text{ ft}$

7. $3 \text{ in.} \approx \underline{\quad? \quad} \text{ mm}$

8. $130 \text{ yd} \approx \underline{\quad? \quad} \text{ m}$

9. $120 \text{ L} \approx \underline{\quad? \quad} \text{ gal}$

10. $52 \text{ m} \approx \underline{\quad? \quad} \text{ ft}$

11. $150 \text{ kg} \approx \underline{\quad? \quad} \text{ lb}$

12. $6 \text{ m} \approx \underline{\quad? \quad} \text{ in.}$

13. $2 \text{ ft} \approx \underline{\quad? \quad} \text{ cm}$

14. $40 \text{ yd} \approx \underline{\quad? \quad} \text{ m}$

15. $3 \text{ lb} \approx \underline{\quad? \quad} \text{ g}$

Compare. Write $<$, $>$, or $=$ for each \bigcirc .

16. $7 \text{ ft} \bigcirc 421 \text{ cm}$

17. $80 \text{ cm} \bigcirc 4.5 \text{ ft}$

18. $8.5 \text{ lb} \bigcirc 5 \text{ kg}$

19. $44 \text{ mm} \bigcirc 5 \text{ in.}$

20. $32.8 \text{ ft} \bigcirc 10 \text{ m}$

21. $5 \text{ km} \bigcirc 3.2 \text{ mi}$

22. $22 \text{ gal} \bigcirc 55 \text{ L}$

23. $8.2 \text{ qt} \bigcirc 10.1 \text{ L}$

24. $1.5 \text{ mi} \bigcirc 1.7 \text{ km}$

Mixed Review

Use inverse operations to solve. Check your solutions.

25. $x + 7 = 19$

26. $y - 9 = 7$

27. $m + 19 = 41$

28. $r - 27 = 15$

29. $z + 4.7 = 11$

30. $w - 7.8 = 5.6$

Find the difference.

31. $^{-}5 - ^{+}7$ _____

32. $^{+}8 - ^{+}10$ _____

33. $^{+}6 - ^{-}9$ _____

Name _____

Appropriate Tools and Units

Measure the line segment to the given length.

1. nearest inch; nearest half inch

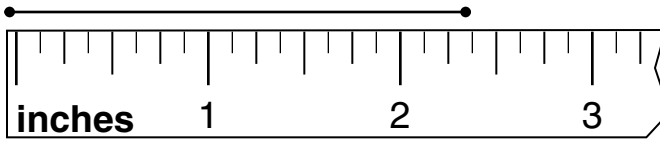

2. nearest centimeter; nearest millimeter

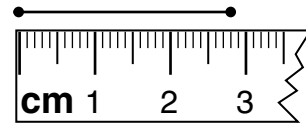

3. nearest half inch; nearest quarter inch

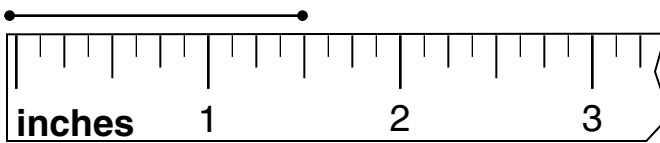

4. nearest centimeter; nearest millimeter

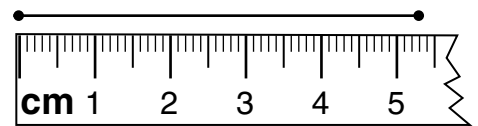

5. nearest inch; nearest half inch



6. nearest centimeter; nearest millimeter



Tell which measure is more precise.

7. 9 lb or 142 oz
- _____

8. 6 c or 50 oz
- _____

9. 350 cm or 420 mm
- _____

10. 9 mg or 12 kg
- _____

11. 2 yd or 71 in.
- _____

12. 1 L or 980 mL
- _____

Name an appropriate customary or metric unit of measure for each item.

13. the amount of formula in a baby's bottle
- _____

14. the weight of a laptop computer
- _____

15. the length of the eraser on a pencil
- _____

16. the weight of a box of tissues
- _____

Mixed Review

Use inverse operations to solve. Check your solution.

17. $5w = 30$

18. $\frac{m}{4} = 5$

19. $72 = 9h$

20. $\frac{w}{3} = 17$

Write the ratio in three ways.

21. five to nine _____

22. ten to seven _____

Name _____

Problem Solving Skill: Estimate or Find Exact Answer

Decide whether you need an estimate or an exact answer. Solve.

1. You and several friends are setting up tents on a camping trip. It takes 25 min to set up a tent. If you begin at 1:00 P.M., can you set up 7 tents by 3:00 P.M.?

2. Your campsite is a rectangle 61 ft by 33 ft. You have 200 ft of rope. Do you have enough to run the rope around the entire perimeter of the campsite?

3. You brought 9 bags of snacks with you for the 2-day trip. Each bag cost \$1.59. If you paid for the snacks with a \$20 bill, how much change did you receive?

4. On the second day of the trip, your group hikes for $3\frac{3}{4}$ hr. If you average 3.8 mi per hr, will you have reached your goal of covering at least 10 mi?

5. The odometer on the van you rented for the trip read 5,398.2 mi when you left home. It read 5,702.1 mi when you arrived back home. How far did you drive?

6. Everyone agrees that they want to get at least 8 hr sleep per night. If you want to wake up at 6:45 A.M. each morning, what is the latest you can fall asleep each night?

7. The trip to the campground usually takes about $3\frac{1}{4}$ hr. If you leave home at 8:45 A.M. and make two 20-min stops, would you arrive by noon?

8. On the last night of the camping trip, you have 1 gal of water left. After making 3 cans of soup that each required 16 oz of water, how many ounces of water do you have left?

Mixed Review

Find the sum or difference. Write the answer in simplest form.

- | | | | | |
|---|--|--|--|--|
| 9. $\frac{1}{2} - \frac{1}{3}$
_____ | 10. $\frac{2}{5} - \frac{1}{4}$
_____ | 11. $\frac{2}{5} - \frac{1}{6}$
_____ | 12. $\frac{5}{8} - \frac{1}{4}$
_____ | 13. $\frac{7}{8} - \frac{3}{4}$
_____ |
| 14. $\frac{7}{10} + \frac{1}{5}$
_____ | 15. $\frac{1}{6} + \frac{1}{3}$
_____ | 16. $\frac{3}{5} + \frac{1}{3}$
_____ | 17. $\frac{1}{9} + \frac{1}{2}$
_____ | 18. $\frac{2}{9} + \frac{1}{3}$
_____ |

Find the sum.

- | | | | |
|------------------------|------------------------|------------------------|------------------------|
| 19. $-3 + -7$
_____ | 20. $-4 + +6$
_____ | 21. $+5 + -8$
_____ | 22. $+4 + +7$
_____ |
|------------------------|------------------------|------------------------|------------------------|

Name _____

Perimeter

Find the perimeter.

1.

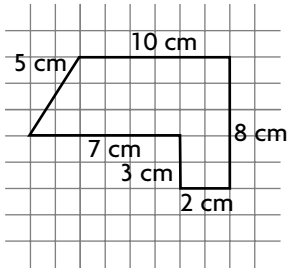

2.

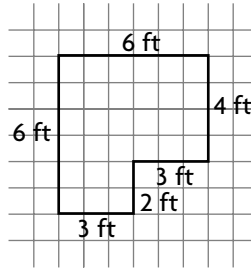

3.

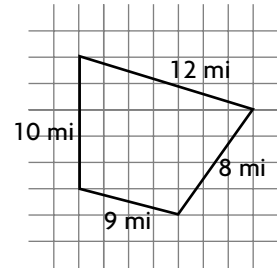

Find the unknown length.
Then find the perimeter.

4.

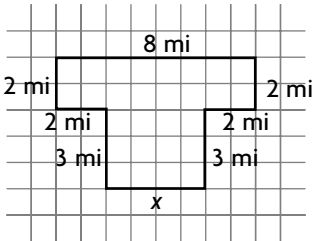

The perimeter is given.
Find the unknown length.

5.

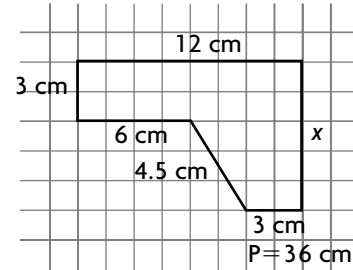

Mixed Review

Use a proportion to change to the given unit.

6. 18 yd = _____ in.

7. 22 qt = _____ gal

8. 435 min = _____ hr

9. 8.5 gal = _____ pt

10. 348 in. = _____ ft

11. $12\frac{1}{2}$ lb = _____ oz

Write a numerical or algebraic expression for the word expression.

12. One hundred divided by the sum of k and m . _____

13. v less than two thousand forty-seven. _____

14. w multiplied by the product of a and b . _____

Name _____

Problem-Solving Strategy: Draw a Diagram

Solve the problem by drawing a diagram.

A contractor built a house in the shape of a rectangle. The house is 64 ft long and 48 ft wide. There is a wall running across the width of the house. The wall divides the length of the house into two sections, one larger than the other. The distance from the wall to one end of the house is 3 times the distance from the wall to the other end.

- | | |
|---|---|
| <p>1. Describe the shape of the larger section of the house. Give the dimensions of the figure.</p> <p>_____</p> | <p>2. Molding is going to be installed around the entire floor of the larger section of the house. How many feet of molding will be needed?</p> <p>_____</p> |
| <p>3. There are 3 doors leading into the house. Each door is 3 ft wide. What is the perimeter of the house if the doors are not included?</p> <p>_____</p> | <p>4. There are beams around the perimeter of the house every 16 in. If there is a beam in each corner, what is the total number of beams</p> <p>_____</p> |
| <p>5. There are plans to add a garage to the side of the house. The length of the rectangular garage will be 3 ft greater than its width. If the perimeter of the garage will be 90 ft, find its length and width.</p> <p>_____</p> | <p>6. The garage will be attached to the house along one of its shorter sides. What will be the perimeter of the house and garage when the garage is complete?</p> <p>_____</p> |

Mixed Review

Write the ratio as a percent.

- | | | | |
|---------------------|-----------------------|----------------------|----------------------|
| 7. $\frac{74}{100}$ | 8. $\frac{6}{100}$ | 9. $\frac{19}{100}$ | 10. $\frac{40}{100}$ |
| _____ | _____ | _____ | _____ |
| 11. $\frac{1}{100}$ | 12. $\frac{100}{100}$ | 13. $\frac{50}{100}$ | 14. $\frac{98}{100}$ |
| _____ | _____ | _____ | _____ |

Use a proportion to change to the given unit.

15. 2,400 mL = _____ L 16. 5.8 kg = _____ g 17. 150 cm = _____ m
18. 0.7 g = _____ mg 19. 1,300 m = _____ km 20. 7,500 L = _____ kL

Name _____

Circumference

Find the circumference of the circle. Use 3.14 or $\frac{22}{7}$ for π . Round to the nearest whole number.

1.

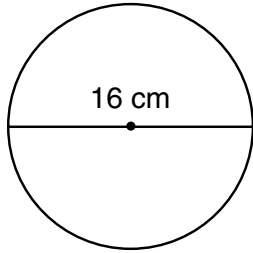

2.

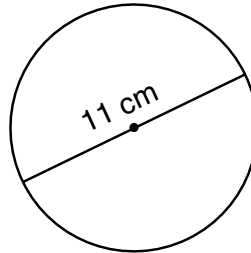

3.

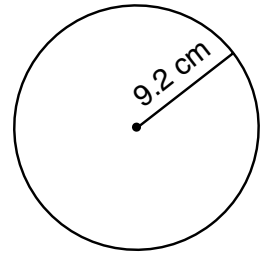

4.

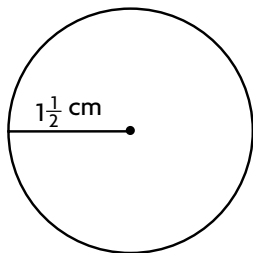

5.

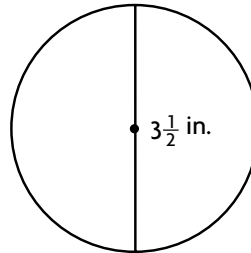

6.

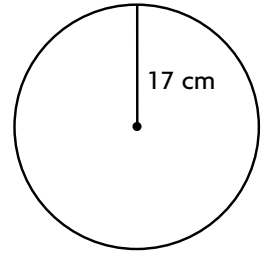

7.

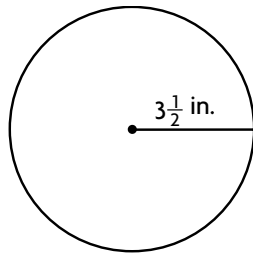

8.

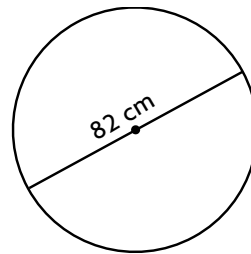

9.

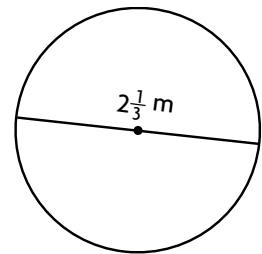

Mixed Review

Use inverse operations to solve. Check your solution.

10. $3x = 12$

11. $40 = 8m$

12. $\frac{y}{3} = 6$

13. $\frac{h}{7} = 6$

Find the sale price.

14. regular price:

\$48.00

20% off

15. regular price:

\$72.00

30% off

16. regular price:

\$120.00

60% off

17. regular price:

\$95.00

25% off

Name _____

Estimate and Find Area

Estimate the area of the figure. Each square is 1 in.^2

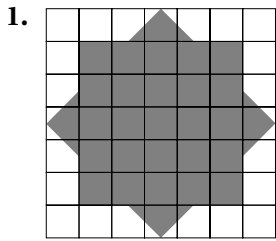

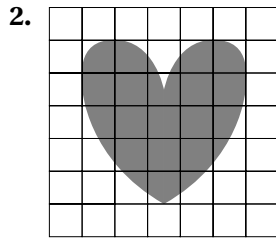

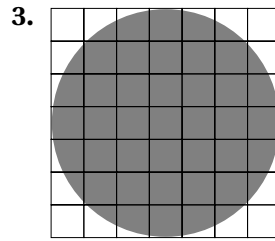

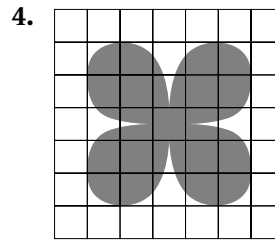

Find the area.

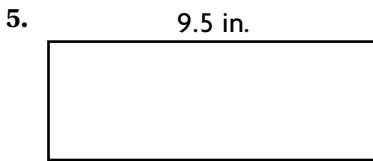

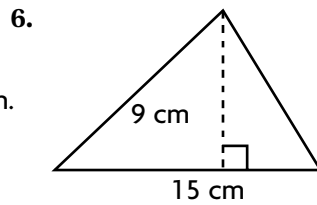

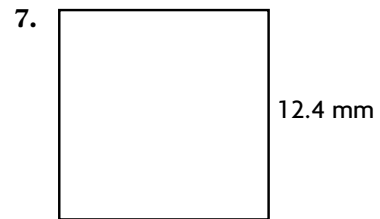

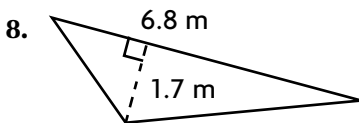

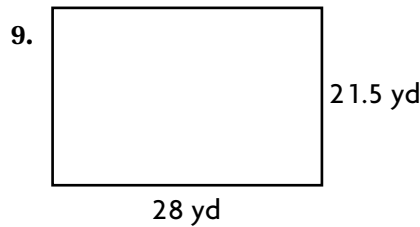

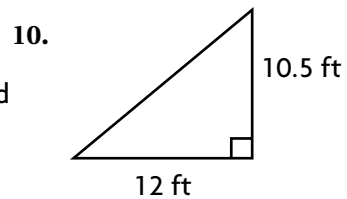

Mixed Review

Find the circumference of the circle. Use $\pi = 3.14$.

11. $d = 17 \text{ cm}$

12. $d = 3.5 \text{ in.}$

13. $r = 11 \text{ mm}$

14. $r = 6.1 \text{ ft}$

Solve and check.

15. $x + 7 = 19$

16. $30 = a + 13$

17. $-45 = 22.5 + n$

18. $c + 2.3 = 9.1$

Name _____

Areas of Parallelograms and Trapezoids

Find the area of each figure.

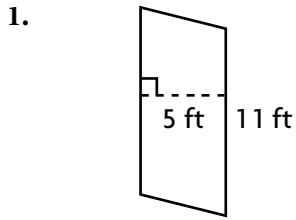

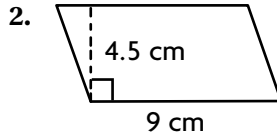

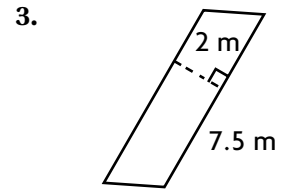

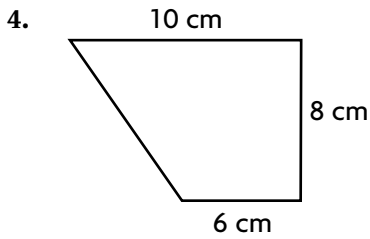

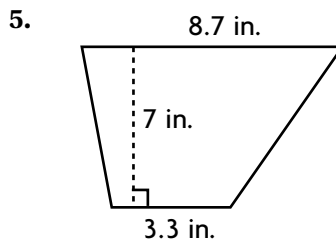

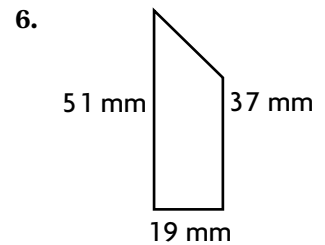

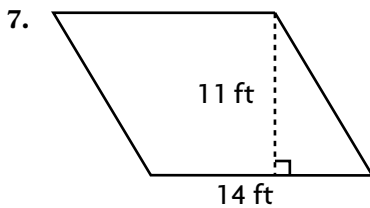

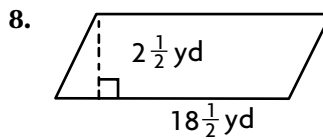

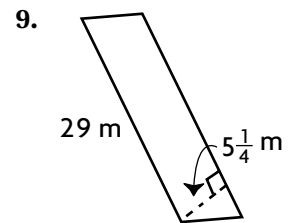

Mixed Review

Tell which measurement is more precise.

10. 10 ft or 12 in.

11. 2 T or 2,000 lb

12. 4 pt or 1 gal

13. 2 kg or 8 g

Evaluate the expression for $x = -2, 0,$ and 4 .

14. $6 - \frac{x}{2}$

15. $5x + 12$

16. $-2 - 3x$

17. $(-x + 2) \cdot 3$

Name _____

Areas of Circles

Find the area of each circle to the nearest whole number.

1.

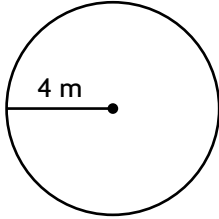

2.

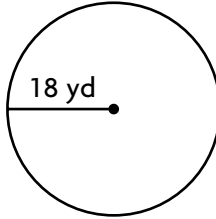

3.

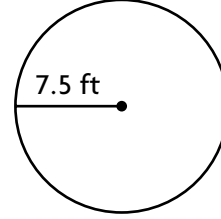

4. $r = 17$ yd _____ 5. $d = 38$ ft _____ 6. $r = 5.6$ m _____

7. $d = 10$ mm _____ 8. $r = 2.2$ mi _____ 9. $d = 54$ cm _____

10. $r = 21$ ft _____ 11. $d = 1.8$ mi _____ 12. $r = 15.5$ in. _____

13. $d = 30$ cm _____ 14. $r = 6.6$ yd _____ 15. $d = 16$ m _____

Find the area of the semicircle or quarter circle to the nearest whole number. Use 3.14 for π .

16.

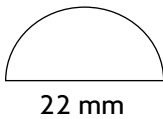

17.

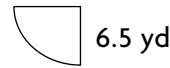

Mixed Review

A number cube is numbered 1 through 6. Find each probability.

18. P(3) _____ 19. P(1 or 6) _____ 20. P(8) _____ 21. P(even) _____

Compare the numbers. Write $<$, $>$, or $=$.

22. 0.01 _____ 0.11 23. 19.9 _____ 19.90 24. 0.411 _____ 0.401 25. 1.575 _____ 1.757

Name _____

Surface Areas of Prisms and Pyramids

Find the surface area.

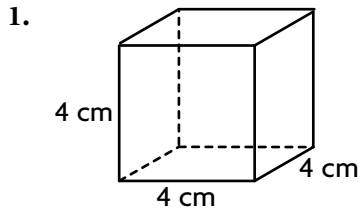

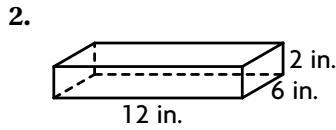

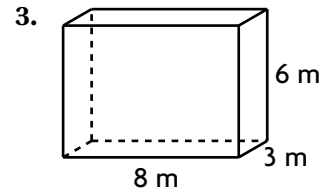

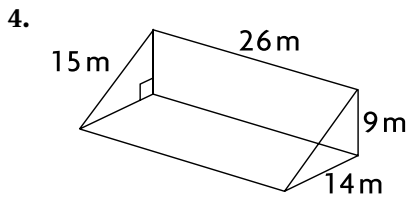

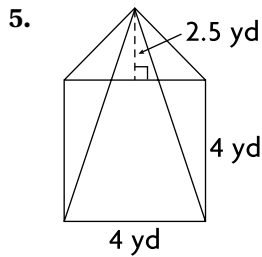

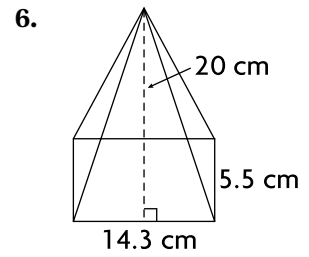

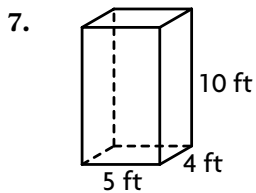

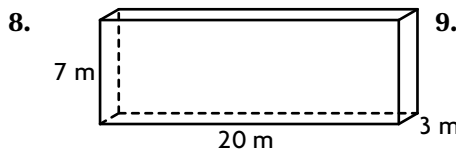

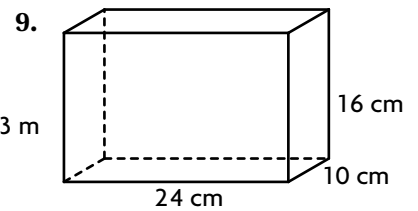

Mixed Review

Evaluate the expression for $m = 6$ and $n = -2$.

10. $m \div 3 - 4n$

11. $(50 - m^2) \times 3 + n$

12. $12n - 5 \times -2m$

Find the LCM of each pair of numbers.

13. 4, 18 _____

14. 6, 32 _____

15. 3, 11 _____

Name _____

Estimate and Find Volume

Find the volume.

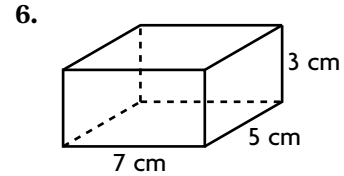
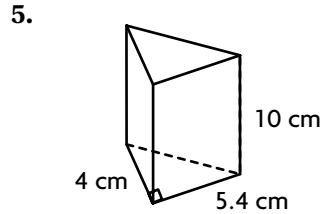
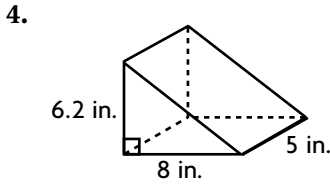
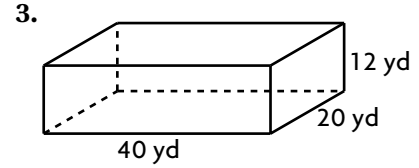
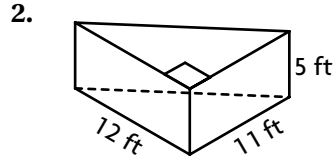
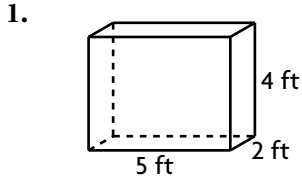

Find the unknown length.

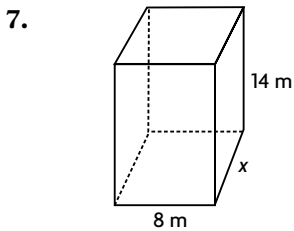

$V = 672 \text{ m}^3$

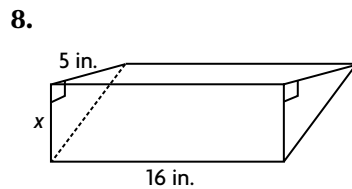

$V = 160 \text{ in.}^3$

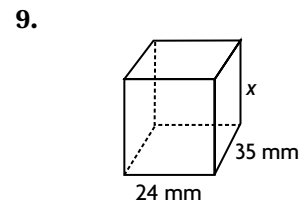

$V = 17,640 \text{ mm}^3$

Mixed Review

Find the circumference of the circle to the nearest whole number.

Use 3.14 or $\frac{22}{7}$ for π .

10. $r = 4 \text{ in.}$

11. $d = 6.3 \text{ cm}$

12. $r = 12 \frac{1}{2} \text{ m}$

13. $d = 9 \frac{1}{3} \text{ yd}$

14. $r = 110 \text{ mm}$

15. $d = 15.7 \text{ ft}$

Find the unknown dimension.

16. scale: 1 cm:12 m
drawing length: 18 cm
actual length: _____

17. scale: 3 cm: 2 mm
drawing length: _____
actual length: 11 mm

Name _____

Problem Solving Strategy: Make a Model

Find the volume. Then double the dimensions. Find the new volume.

1.

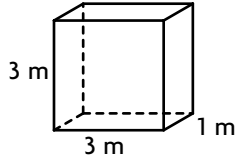

2.

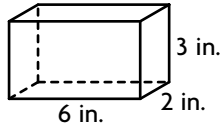

3.

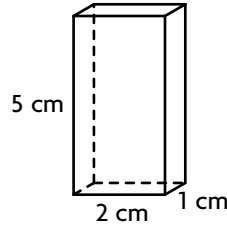

4.

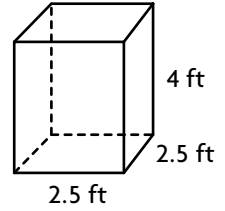

Find the volume of each prism. Then halve the underlined dimensions and find the new volume.

	Length	Width	Height	Volume	New Volume
5.	5 m	<u>4 m</u>	2 m		
6.	12 ft	8 ft	<u>10 ft</u>		
7.	24 cm	<u>3 cm</u>	6 cm		
8.	<u>9 in.</u>	6 in.	10 in.		

Mixed Review

A number cube is numbered 1 through 6. Find each probability.

9. $P(5)$ _____ 10. $P(\text{not } 2)$ _____ 11. $P(\text{even})$ _____ 12. $P(1 \text{ or } 3)$ _____

Solve and check.

13. $n + 8 = 57$

14. $30 = x + 82$

15. $k + 2\frac{1}{3} = 11$

16. $22 = 7.34 + b$

17. $17\frac{1}{2} + m = 23\frac{1}{4}$

18. $-44 = 37 + a$

Algebra: Volumes of Pyramids

Find the volume.

1.

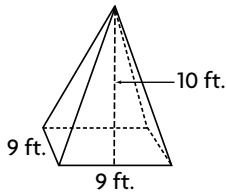

2.

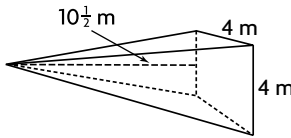

3.

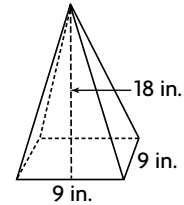

4.

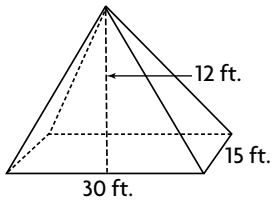

5.

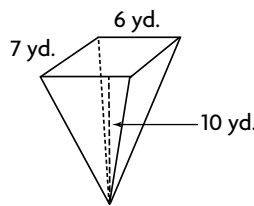

6.

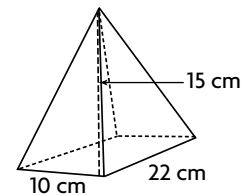

7. rectangular pyramid: $l = 36$ in.,
 $w = 50$ in., $h = 60$ in.

8. square pyramid: $l = 14$ yd,
 $w = 14$ yd, $h = 25$ yd

9. rectangular pyramid: $l = 6$ cm,
 $w = 5$ cm, $h = 6$ cm

10. square pyramid: $l = 10$ m,
 $w = 10$ m, $h = 15$ m

Mixed Review

Find the area of each circle to the nearest whole number. Use 3.14 for pi (π).

11. $r = 4$ yd

12. $d = 12$ ft

13. $r = 5.5$ m

14. $d = 7.2$ cm

Use a proportion to change to the given unit.

15. 4 qt = _____ c

16. 26 in. = _____ ft

17. 68 oz = _____ lb

Name _____

Volumes of Cylinders

Find the volume. Round to the nearest whole number.

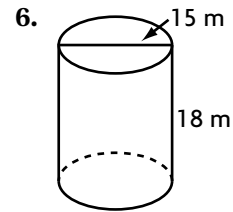
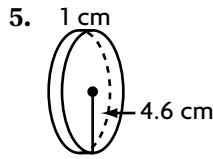
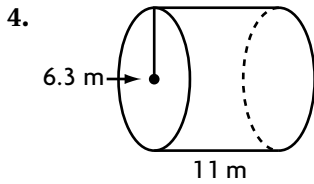
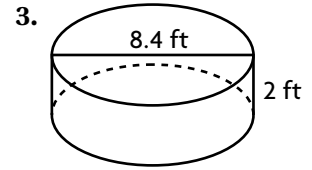
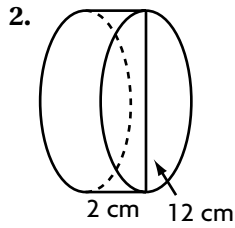
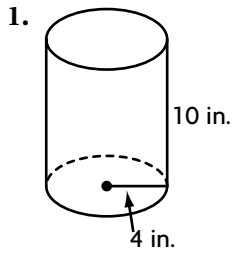

Find the volume of the inside cylinder to the nearest whole number.

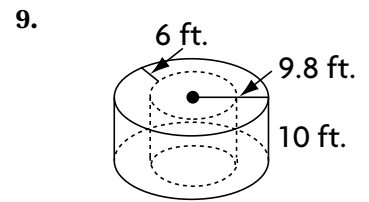
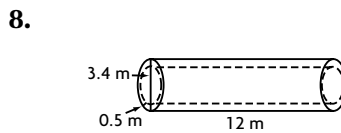
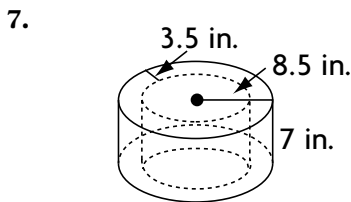

Mixed Review

There are 6 blue socks, 5 red socks, and 10 black socks in a drawer. Without looking, you pull out 2 socks. Find the probabilities.

10. $P(\text{red, black})$ _____

11. $P(2 \text{ blue})$ _____

12. $P(\text{black, blue})$ _____

Find the sum.

13. $7 + -8$

14. $-3 + 14$

15. $-9 + -27$

16. $-15 + 3$

17. $22 + -18$

Name _____

Problem-Solving Strategy: Find a Pattern

Solve the problems by finding the pattern.

- | | |
|---|--|
| <p>1. Laura is reading a novel she found in the school library. She read 15 pages the first day. Then each day she read 6 more pages than the day before. How many pages did she read on the eighth day?</p> <hr/> | <p>2. When Jeff played his new computer game for the first time, he scored 10,000 points. Each time he played, he increased his score by 15,000 points. How many games did Jeff have to play to reach a score of 100,000?</p> <hr/> |
| <p>3. For her pet store's grand opening, Mrs. Santos gave 7 prizes. The seventh-prize winner received a \$1 gift certificate, the sixth-prize winner a \$2 certificate, the fifth-prize winner a \$4 certificate, the fourth-prize winner an \$8 certificate. What was the value of the first-prize certificate?</p> <hr/> | <p>4. Kevin is laying tile in his kitchen. The area of the kitchen is 96 ft^2. Since this is his first tile job, he is working at it slowly. He tiled 7 ft^2 the first day, 14 ft^2 the second day, and 21 ft^2 the third day. If this pattern continues, how many days will it take Kevin to tile the entire floor?</p> <hr/> |
| <p>5. The school band is practicing for a competition to be held in 8 weeks. The band practices 1 hr a day for the first week. It practices $1\frac{1}{4}$ hr a day for the second week, $1\frac{1}{2}$ hr a day the third week, and $1\frac{3}{4}$ hr a day the fourth week. If this pattern continues, how many hours will the band practice during the eighth week?</p> <hr/> | <p>6. A synchronized swim team makes different patterns in the water by joining their arms and legs. One swimmer begins the pattern. After 5 sec, two swimmers join. At 10 sec, two more join. At 15 sec, another two join the group. If this pattern continues, how many swimmers will be in the group after 30 sec?</p> <hr/> |

Mixed Review

Find the volume of the cylinder. Round to the nearest whole number.

7. diameter = 13 in.
height = 5 in.

8. radius = 7.5 cm
height = 24 cm

9. diameter = 30 m
height = 73 m

Find the volume.

10. $24 + \sqrt{64} - 6^2 - \sqrt{81}$

11. $\sqrt{144} + 7^2 - \sqrt{36} - 5^2$

Name _____

Patterns in Sequences

Write the rule for each sequence.

1. 17, 22, 28, 35, ...

2. 81, 69, 57, 45, ...

3. 1, 5, 25, 125, ...

4. 117, 116, 113, 108, ...

5. 700, 70, 7, 0.7, ...

6. 1,000, 500, 250, 125, ...

7. 77, 79, 83, 85, 89, ...

8. 19, 16.5, 14, 11.5, ...

9. 64, 55, 47, 40, ...

Find the next three terms in each sequence

10. 17, 34, 68, 136, ...

11. 325, 320, 310, 295, ...

12. 14.6, 14.5, 14.3, 14.0, ...

13. 3, 9, 27, 81, ...

14. 535, 529, 522, 514, ...

15. 33, 45, 57, 69, ...

16. 1,458, 486, 162, 54, ...

17. 390, 401, 414, 429, ...

18. 7, -14, 28, -56, ...

Mixed Review

Find the surface area.

19. rectangular prism

$l = 18 \text{ cm}$

$w = 14 \text{ cm}$

$h = 8 \text{ cm}$

20. cube

edge = 5.5 in.

21. rectangular prism

$l = 7.3 \text{ yd}$

$w = 4.1 \text{ yd}$

$h = 6.5 \text{ yd}$

The map distance is given. Write and solve a proportion to find the actual distance. Use a map scale of $1 \text{ cm} = 68 \text{ mi}$.

22. 4 cm

23. $10\frac{1}{2} \text{ cm}$

24. 5 cm

25. 15 cm

26. $7\frac{1}{2} \text{ cm}$

27. $12\frac{1}{4} \text{ cm}$

Name _____

Number Patterns and Functions

Write an equation to represent the function.

1.

w	3	9	15	21	33
l	1	3	5	7	11

2.

x	2	4	6	8	10
y	6	10	14	18	22

3.

s	14	12	8	6	4
t	12.8	10.8	6.8	4.8	2.8

4.

m	2	6	7	9	11
n	8	24	28	36	44

Write an equation to represent the function. Then find the missing term.

5.

j	11	15	19	23	27
k	23	27	31		39

6.

a	32	26	22	18	14
b	16		11	9	7

7.

e	2	6	7	9	11
f	10	30	35	45	

8.

x	2	3	4	5	6
y		8	11	14	17

Write an equation for the function. Possible answers are given.

9. The width of a rectangle is $\frac{1}{3}$ its length. _____

10. An elevator travels at the rate of 5 floors per minute. _____

11. Each person on the bus has two suitcases. _____

Mixed Review

Write as a percent.

12. 0.002

13. $\frac{7}{20}$

14. 1.18

15. $\frac{1}{25}$

Write the prime factorization in exponent form.

16. 90

17. 252

18. 675

19. 500

Name _____

Geometric Patterns

Draw the next three figures in each geometric pattern.

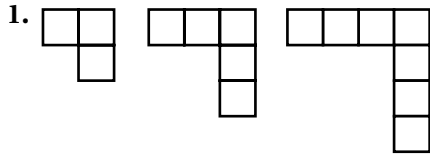



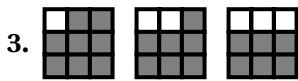

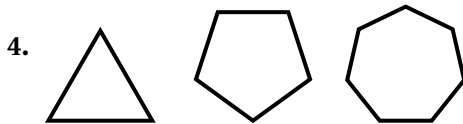

Describe the next two solid figures you would draw for the pattern.

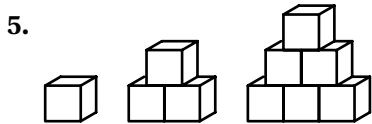

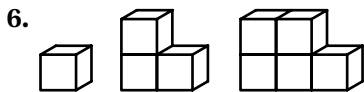

Mixed Review

Tell which measurement is more precise.

7. 38 oz or 6 lb

8. 14.5 gal or 20 c

9. 41 cm or 41 m

Write the fraction as a mixed number or a whole number.

10. $\frac{51}{8}$ _____

11. $\frac{19}{5}$ _____

12. $\frac{23}{2}$ _____

13. $\frac{91}{7}$ _____

Transformations of Plane Figures

Tell which type or types of transformations the second figure is of the first figure. Write *translation*, *rotation*, or *reflection*.

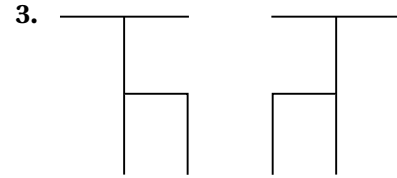
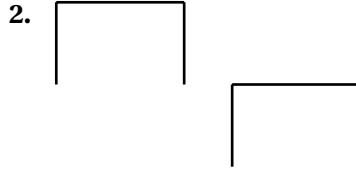
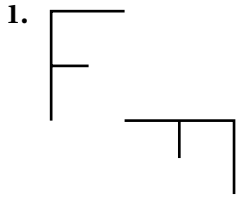

Draw a 90° rotation and horizontal reflection of each figure.

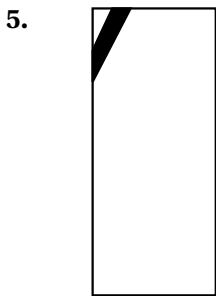
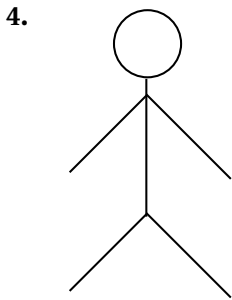

Mixed Review

Find the volume.

6. rectangular prism
 $l = 7$ yd; $w = 9$ yd
 $h = 14$ yd

7. cube
 side = 12 cm

8. rectangular prism
 $l = 3.6$ m; $w = 0.8$ m
 $h = 1.5$ m

Use a proportion to change to the given unit.

9. 10.5 m = _____ cm

10. 670 g = _____ kg

11. 56 L = _____ mL

Name _____

Tessellations

Make the tessellation shape described by each pattern. Then form two rows of a tessellation.

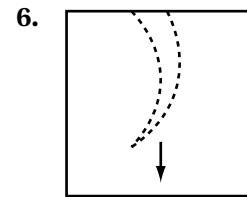
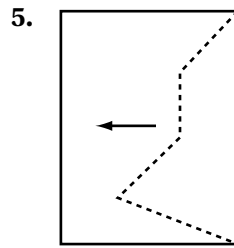
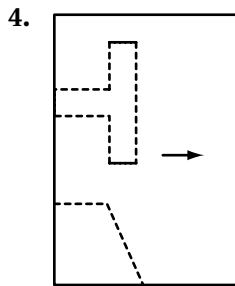
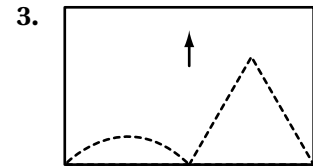
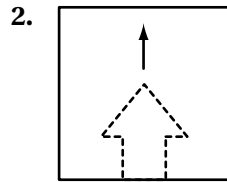
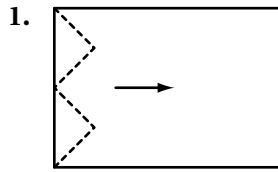

Tell whether the shape can be used to form a tessellation. Write *yes* or *no*.

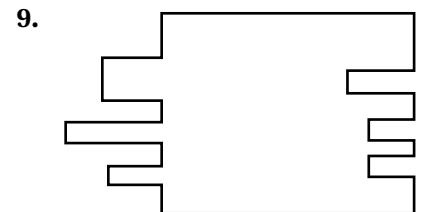
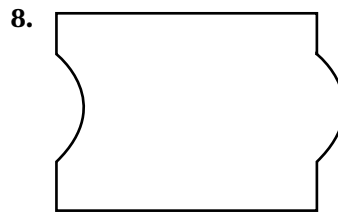
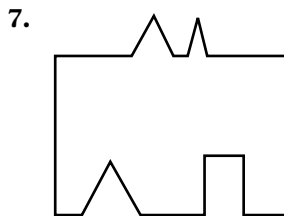

Mixed Review

Find the area of each figure.

10. square
side = 8.3 in.

11. triangle
b = 16 cm; h = 11 cm

12. rectangle
l = 37 ft; w = 21 ft

Find the difference. Write the answer in simplest form.

13. $7\frac{1}{3} - 3\frac{3}{4}$

14. $4\frac{2}{5} - 1\frac{2}{3}$

15. $9\frac{3}{8} - \frac{4}{5}$

16. $30 - 27\frac{7}{8}$

Name _____

Problem-Solving Strategy: Make a Model

Solve the problem by making a model.

1. Carol is making a design from the shape below. She wants the shape to tessellate a plane. Can she use this shape?



2. Will this shape tessellate a plane? Explain.

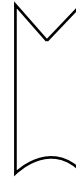

3. Adam created this shape for a tile floor. Will his shape tessellate a plane?

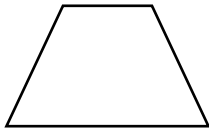

4. Draw a figure that does NOT tessellate a plane.

Mixed Review

Find the unknown dimension.

5. scale: 1 in.:5 yd

6. scale: 3 cm:35 m

7. scale: 5 cm:3 mm

drawing length: 8 in.

drawing length: _____

drawing length: 27 cm

actual length: _____

actual length: 525 m

actual length: _____

Find the angle measures.

8. $\angle 1 =$ _____

9. $\angle 2 =$ _____

10. $\angle 3 =$ _____

11. $\angle 4 =$ _____

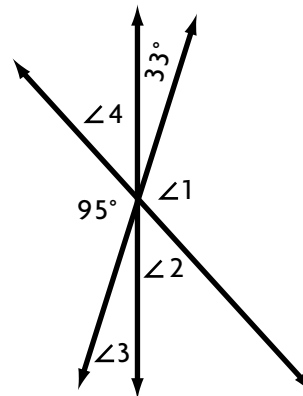

Name _____

Transformations of Solid Figures

Tell how many ways you can place the solid figure on the outline.

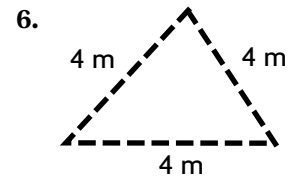
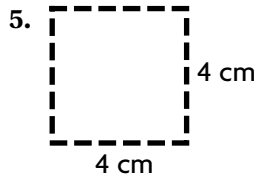
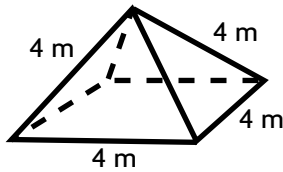
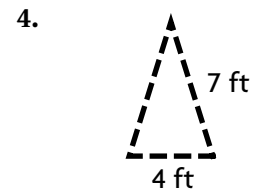
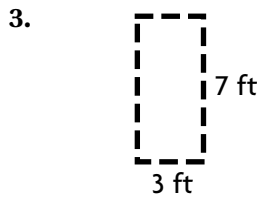
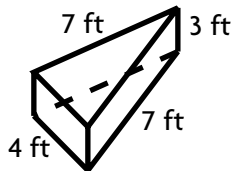
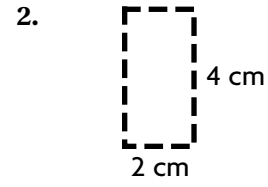
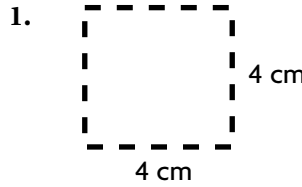
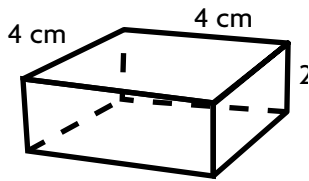

Mixed Review

Write the next three terms in each sequence.

7. 5, 7, 9, 11, 13, _____

8. 2, 6, 18, 54, _____

9. 12, 8, 4, 0, _____

10. $-5, 10, -20, 40, \dots$

Find the circumference of the circle. Use 3.14 for pi (π).

11. $r = 15.25$ km

12. $d = 33$ m

13. $r = 5.5$ ft

14. $d = 46$ in.

15. $r = 8.5$ cm

16. $d = 12.3$ dm

Symmetry

Draw lines of symmetry.

1.

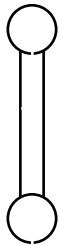

2.

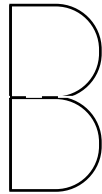

3.

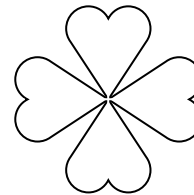

Complete the other half of the figure across the line of symmetry.

4.

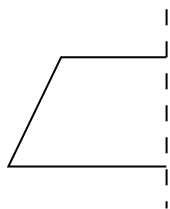

5.



6.



Tell whether each figure has rotational symmetry, and, if so, identify the symmetry as a fraction of a turn and in degrees.

7.

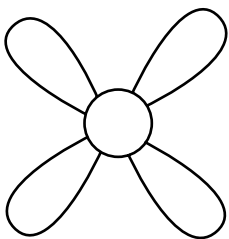

8.

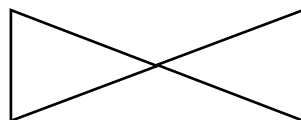

9.

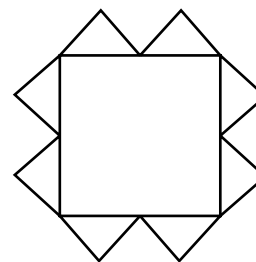

Mixed Review

Write the percent as a decimal.

10. 26%

11. 9%

12. 71%

13. 16.5%

Write the mixed number as a fraction.

14. $3\frac{3}{4}$

15. $7\frac{1}{8}$

16. $1\frac{5}{6}$

17. $10\frac{3}{5}$

Name _____

Inequalities on a Number Line

Graph the solutions of the inequality.

1. $x > 5$

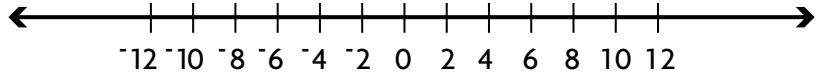

2. $x \leq -2$

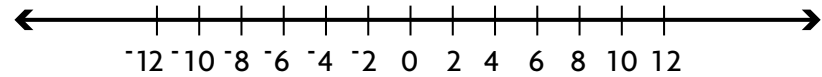

3. $x \geq -1$

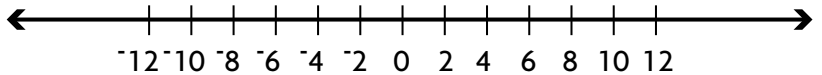

4. $x < 7$

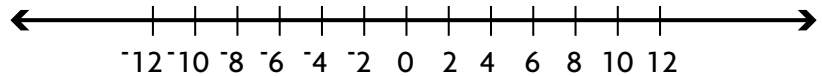

Solve the inequality and graph the solutions.

5. $x + 3 > 7$ _____

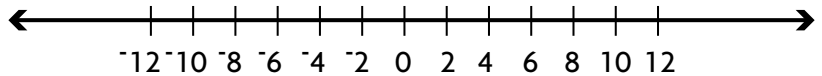

6. $n - 5 < 3$ _____

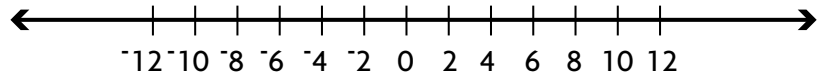

7. $2p \leq 6$ _____

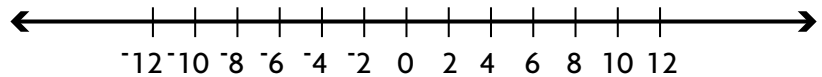

8. $k + 7 > 7$ _____

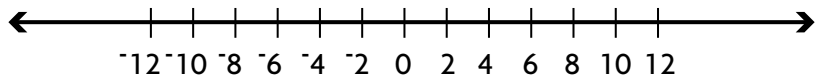

For 9–10, write an algebraic inequality for the word sentence.

9. The value of m is greater than or equal to fifteen.

10. The value of w is less than negative forty-three.

Mixed Review

Find the area of each figure.

11. a parallelogram with base 6.2 ft and height 2.7 ft

12. a trapezoid with bases 23 cm and 19 cm and height 11.4 cm

13. a parallelogram with base 32.8 m and height 8.4 m

Use a proportion to change to the given unit.

14. 3,500 lb = _____ T

15. 126 in. = _____ yd

16. 41 qt = _____ gal

Name _____

Graph on the Coordinate Plane

Write the ordered pair for each point on the coordinate plane.

- | | | |
|-------------------|-------------------|-------------------|
| 1. point <i>A</i> | 2. point <i>B</i> | 3. point <i>C</i> |
| _____ | _____ | _____ |
| 4. point <i>D</i> | 5. point <i>E</i> | 6. point <i>F</i> |
| _____ | _____ | _____ |
| 7. point <i>G</i> | 8. point <i>H</i> | 9. point <i>J</i> |
| _____ | _____ | _____ |

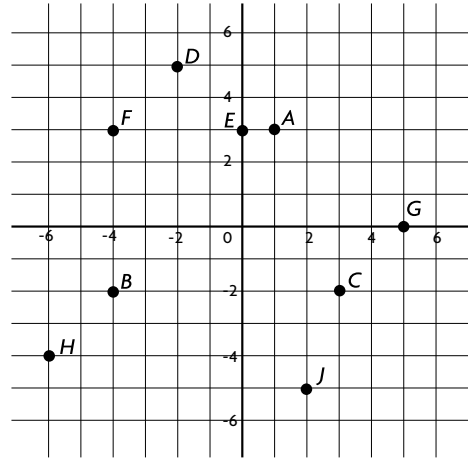

Use the coordinate plane above. Identify the points located in the given quadrant.

- | | |
|----------------------|---------------------|
| 10. <i>I</i> _____ | 11. <i>II</i> _____ |
| 12. <i>III</i> _____ | 13. <i>IV</i> _____ |

Plot the points on the coordinate plane.

- | | | |
|----------------------|---------------------|---------------------|
| 14. <i>S</i> (0,5) | 15. <i>T</i> (2,2) | 16. <i>U</i> (-5,4) |
| 17. <i>V</i> (-2,-2) | 18. <i>W</i> (5,-2) | 19. <i>X</i> (6,0) |

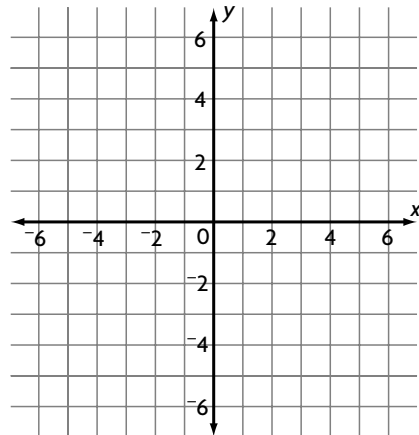

Mixed Review

Find the percent of the number.

- | | | | |
|----------------|---------------|----------------|-----------------|
| 20. 78% of 152 | 21. 12% of 37 | 22. 57% of 238 | 23. 0.6% of 200 |
| _____ | _____ | _____ | _____ |

Find the circumference of each circle. Use 3.14 for π .

- | | | | |
|----------------|-----------------|----------------|-----------------|
| 24. $r = 7$ in | 25. $d = 12$ ft | 26. $d = 15$ m | 27. $r = 30$ cm |
| _____ | _____ | _____ | _____ |

Name _____

Graph Functions

Complete the function table.

1.

x	1	2	3	4	5
y	3	4	5	___	___

2.

x	1	2	3	4	5
y	5	10	15	___	___

3. Graph the data from Exercise 1 on the coordinate plane.

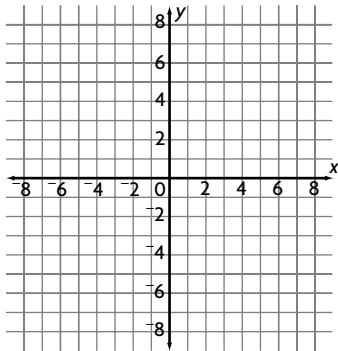

4. Graph the data from Exercise 2 on the coordinate plane.

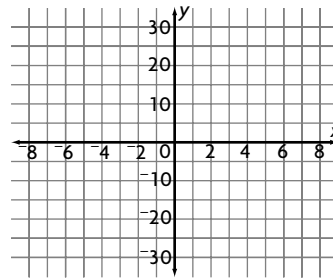

5. Write an equation relating y to x for the data in Exercise 1.

6. Write an equation relating y to x for the data in Exercise 2.

7. Use the equation $y = x - 5$ to make a function table. Use the integers from -3 to 3 as values of x .

x							
y							

Mixed Review

Find the number of possible choices for each situation.

8. 5 flavors of ice cream and 4 toppings

9. 4 shirts, 6 ties, and 2 jackets

10. 3 kinds of pancakes and 4 kinds of syrup

Evaluate the expression for $n = -3, -1,$ and 4 .

11. $3n - 2(n + 5) + n$

12. $5 + 2n - (6 + n)$

Name _____

Problem Solving Skill: Make Generalizations

Solve by making a generalization.

Anita uses 2.5 c of flour to make a dozen muffins. The table shows the number of dozens of muffins made, x , for different amounts of flour, y .

x (doz)	2	4	6	8	10
y (c)	5	10	15	20	25

- What equation can be used to show the amount of flour that Anita uses?

A $y = x - 2.5$ C $y = x + 2.5$
 B $y = x \div 2.5$ D $y = 2.5x$
- How much flour does Anita use to make 16 dozen muffins?

F 6.4 c H 20 c
 G 18.5 c J 40 c

Anita charges \$0.75 for each muffin.

- Write an equation to show the cost, m , when Anita sells n muffins.
- How much will Anita charge for 15 muffins?

Rick spends \$8 on supplies for his dog-grooming business. The table shows his profit, y , for several income amounts, x .

x	\$30	\$35	\$40	\$45
y	\$22	\$27	\$32	\$37

- What equation can be used to show Rick's profit?

A $y = 8 - x$ C $y = \frac{1}{8}x$
 B $y = x - 8$ D $y = x + 8$
- How much profit did Rick make if he earned \$105?

F \$113 H \$101
 G \$109 J \$97

Rick charges \$35 for a regular dog grooming.

- What equation can Rick use to show the amount that he earns, y , when he grooms x dogs?
- How much will Rick earn if he grooms 12 dogs?

Mixed Review

Find the simple interest.

9. principal: \$2,200
 rate: 7.3%
 time: 4 yr

10. principal: \$14,000
 rate: 6.7%
 time: 8 yr

11. principal: \$35,000
 rate: 8.2%
 time: 12 yr

Name _____

Graph Transformations

Transform the figure according to the directions given.
Name the new coordinates.

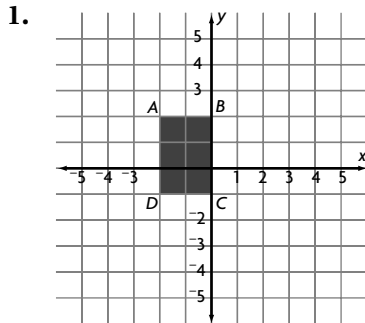

Translate 4 units right
and 3 units up.

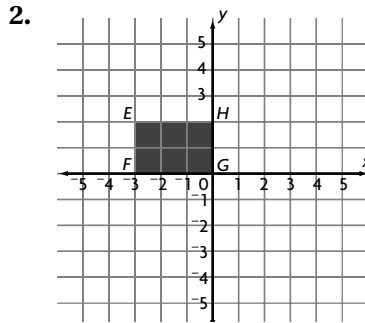

Reflect across the
 x -axis.

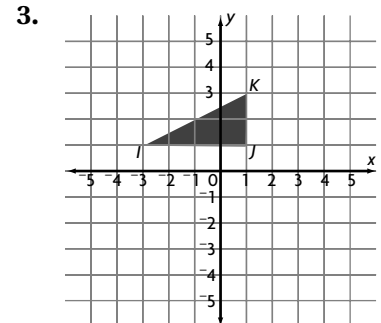

Reflect across the
 x -axis

Rotate the figure around the origin according to the directions given.
Name the new coordinates.

4. 90° clockwise

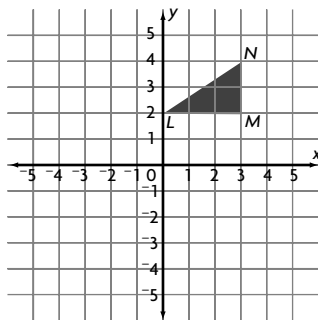

5. 180° counterclockwise

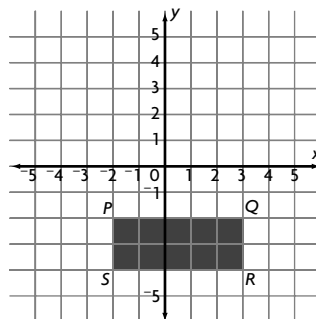

6. 90° counterclockwise

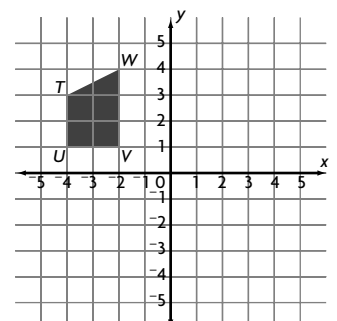

Mixed Review

Find the next three terms in each sequence.

7. 4, 12, 36, 108, ...

8. 27, 19, 11, 3, ...

9. 7, 11, 18, 29, ...

Solve and check.

10. $h + 12 = 37$

11. $m + 8 = 19$

12. $-43 = 4 + p$
